

## User Manual

# ProfiHub B5+ / B5+R / B5+RD

### 5 Channel DP Spur and Repeater component with Redundancy and optional Diagnostics Device

Integrated **Diagnostics Device** (on type B5+RD)

5 Isolated outgoing Channels.

Transparent for all **PROFIBUS DP** protocols.

**RS 485 specifications** for each channel.

**Cable Redundancy**

**Max. 12 Mbps.**

**Max. 31 devices** per channel.

**Max. 1200 m spur line length.**

No limit in serial placement.

Integrated termination facilities.

Configurable grounding system.

**IP 20** classification.

**Extended** temperature range.

**UL and DNV approved**

## Safety Guidelines

This manual contains notices which you should observe to ensure your own personal safety, as well as to protect the product and connected equipment. These notices are highlighted in the manual by a warning sign and are marked as follows according to the level of danger:



Draws your attention to important information on handling the product, a particular part of the documentation or the correct functioning of the product.

## Warning

This device and its components may only be used for the applications described in this manual and only in connection with devices or components that comply with PROFIBUS and an RS 485 interface. This product can only function correctly and safely if it is transported, stored, set up, installed, operated and maintained as recommended.

## Qualified Technicians

Only qualified technicians should be allowed to install and work with this equipment. Qualified technicians are defined as persons who are authorized to commission, to ground, to tag circuits and systems in accordance with established safety practices and standards. It is recommended that the technicians carry a Certified PROFIBUS Installer or Certified PROFIBUS Engineer certificate.

## Disclaimer of Liability

We have checked the contents of this manual as much as possible. Since deviations cannot be precluded entirely, we cannot guarantee full agreement. However, the content in this manual is reviewed regularly and any necessary corrections included in subsequent editions. Suggestions for improvement are welcomed.

## Copyright © 2014 PROCEN TEC

All rights reserved. No part of this publication may be reproduced, stored in a retrieval system, or transmitted, in any form or by any means, electronic, mechanical, photocopying, recording or otherwise, without the prior written permission of the publisher.

**PROCEN TEC**  
**Klopperman 16**  
**2292 JD WATERINGEN**  
**The Netherlands**

**Tel.: +31-(0)174-671800**  
**Fax: +31-(0)174-671801**  
**Email: [info@procentec.com](mailto:info@procentec.com)**  
**Web: [www.procentec.com](http://www.procentec.com)**

## Important Information

### **Purpose of the Manual**

This manual explains how to put the ProfiHub B5+ into operation.

### **Recycling and Disposal**

The parts of the ProfiHub can be recycled. For further information about environment-friendly recycling and the procedure for disposing your old equipment, please contact:

*PROCENTEC  
Klopperman 16  
2292 JD WATERINGEN  
The Netherlands*

*Tel.: +31-(0)174-671800  
Fax: +31-(0)174-671801  
Email: [info@procentec.com](mailto:info@procentec.com)*

### **Document Updates**

You can obtain constantly updated information on PROCENTEC products on the Internet at [www.procentec.com](http://www.procentec.com)

You can also contact PROCENTEC Customer Support:

- by phone at +31-(0)174-671800
- by fax at +31-(0)174-671801
- by email at [support@procentec.com](mailto:support@procentec.com)

## Important Notices

### WARNING

When the product is in use at an ambient temperature of 63 degrees Celsius or 145 degrees Fahrenheit, the housing of the ProfiHub B5+ will be hot. **Do not touch the housing!**

At normal operating temperatures of 25 degrees Celsius, the temperature of the housing will not exceed 35 degrees Celsius.

### WARNING

When the product is in use at an ambient temperature of 63 degrees Celsius or 145 degrees Fahrenheit, the housing of the ProfiHub B5+ will be hot. **Do not touch wires which are in contact with the housing!**

### WARNING

When the product is in use at an ambient temperature of 63 degrees Celsius or 145 degrees Fahrenheit, the housing of the ProfiHub B5+ will be hot. **Use wires suitable for these temperatures!**

HOT HOUSING warning located on the side of the housing. Make sure this warning is visible after wall installation. UL certification demands the warning to be visible during operation.

To comply with UL certification regulations (UL60950-1) the power supply must be a Limited Power Source (LPS) or NEC Class 2 or CEC Class 2 that cannot exceed 100VA.

According to UL60950-1, if a copper PROFIBUS cable is used outside, it is required to install surge protection that is suitable for PROFIBUS.

To comply with UL certification regulations the ProfiHub B5+ is to be used on altitudes under 2000 m.

## Contents

<b>Important Notices .....</b>	<b>4</b>
<b>1 Product Description.....</b>	<b>7</b>
1.1 Product Features.....	8
1.2 Application areas.....	9
1.3 Additional Benefits .....	9
1.4 Channel Structure .....	10
1.5 Grounding System .....	10
1.6 Cable lengths for PROFIBUS DP .....	11
1.7 Cable types for PROFIBUS DP.....	12
1.8 Status LEDs .....	13
1.9 Comparison table .....	14
<b>2 Installation Instructions ProfiHub B5+ .....</b>	<b>15</b>
2.1 Location.....	15
2.2 Position.....	15
2.3 Mounting.....	15
2.4 Power Supply .....	16
2.5 Grounding of the power.....	17
2.6 Relay contact .....	18
2.7 Backbone .....	18
2.8 Spur Segments .....	19
2.9 Termination .....	20
2.10 Baudrate switch.....	21
2.11 Channel Redundancy.....	22
<b>3 Diagnostics Device.....</b>	<b>23</b>
3.1 Setting up the Diagnostics Device .....	24
3.1.1 Enabling the Diagnostics Device .....	24
3.1.2 Changing the default PROFIBUS address .....	24
3.1.3 GSD file.....	25
3.2 Configuring the Diagnostic Device.....	25
3.2.1 Info data (mandatory module).....	25
3.2.2 Alarm Confirmation .....	25
3.2.3 Redundant Status .....	25
3.2.4 Baudrate Status .....	26
3.2.5 Relay Status.....	26
3.2.6 Power Status.....	26
3.2.7 Termination Status.....	27
3.2.8 Channel Status .....	27
3.2.9 Livelist Status.....	27
3.2.10 Statistics (Short Format, Long Format .....	28
3.3 Parameterizing the Diagnostic Device .....	30
3.3.1 Diagnostics .....	30
3.3.2 Statistics.....	31
3.3.3 Extended Diagnostics on Events change .....	31
3.3.4 Extended Diagnostics on Statistics change.....	32
3.3.5 Alarm Relay on Events change .....	33
3.3.6 Alarm relay on Statistics change .....	33
3.3.7 Changing the Diagnostics duration/timeout.....	34
3.3.8 Changing the Device Lost timeout.....	34
3.3.9 Changing the data format .....	35
3.4 ProfiTrace plugin for the Diagnostic Device.....	35

3.4.1	Installing the Plugin.....	35
3.4.2	Using the Plugin.....	36
<b>4</b>	<b>Technical Data ProfiHub B5+ / B5+RD.....</b>	<b>37</b>
	<b>Sales offices and Distributors.....</b>	<b>39</b>
<b>5</b>	<b>Order codes.....</b>	<b>42</b>
<b>6</b>	<b>Glossary.....</b>	<b>43</b>
<b>7</b>	<b>Certificates .....</b>	<b>46</b>
<b>8</b>	<b>Revision History.....</b>	<b>53</b>
<b>9</b>	<b>Notes .....</b>	<b>54</b>

## 1 Product Description

**ProfiHub B5+ is an advanced, flexible and robust network component for PROFIBUS DP installations, to create backbone structures and long multi-device star/tree segments.**

PROFIBUS DP is a high speed communication bus that must comply with strict rules concerning spur lines, because of possible reflections that could lead to communication disturbances. If spur lines or star segments are required, costly investments in repeaters have to be done.

The innovative ProfiHub B5+ is the perfect component for such applications. It is an economic solution to realise reliable spur lines in high speed DP networks. They have the functionality of **5 galvanic isolated transparent repeaters**. This allows network structures with extended spur lines that individually can handle a maximum of 31 devices and a length equal to the main bus. **The ProfiHub B5+ refreshes a received message on one Channel and transfers it to all the other Channels (chicken foot topology).**

Because the ProfiHub B5+ creates isolated segments, the devices can now be removed and added during operation. Also most electrical bus problems and EMC disturbances in a spur do not spread to the other segments. The intelligent logic and isolation circuits of the ProfiHubs do not change the bit width. This means the ProfiHubs do not have limitations in serial placement. The logic also detects the transmission speed automatically.

To assist the installation work, termination is integrated and can be switched on/off. The grounding concept is also selectable: direct or capacitive grounding. The ProfiHubs are powered by a 10 to 24 DC Voltage. For troubleshooting, maintenance and commissioning the ProfiHubs are equipped with LEDs on the outside, which indicate the status of each Channel (Data and Error).

If bus redundancy is enabled, 2 segments will form a redundant pair which is completely compatible with the ABB RLM01. An alarm contact is linked to events based on the status of the power supply and the bus redundancy status.

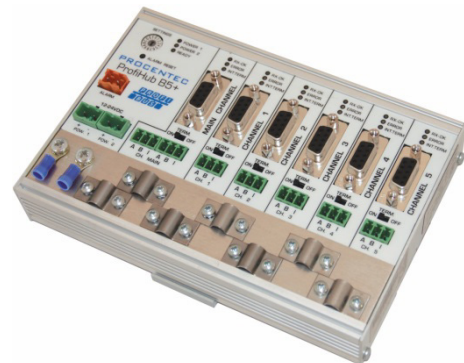

Fig. 1 - ProfiHub B5+

## 1.1 Product Features

- 5 Galvanic isolated outgoing channels (repeater segments).
- Advanced **Diagnostic capabilities** (B5+RD)
- Transparent for all **PROFIBUS DP protocols**.
- **DP - RS 485 specifications** for each channel.
- **Cable redundancy** for channel 4+5
- **9.6 Kbps to 12 Mbps**.
- **31 devices** per channel.
- **1200 m spur line length** (depends on transmission speed).
- **Redundant power supply**
- No limit in serial placement or cascading of ProfiHubs.
- Alarm contact, with manual reset button.
- No address required (except for the B5+RD option).
- Integrated termination facilities (switches).
- Configurable grounding system (direct or capacitive).
- **IP 20** classification
- **Increased** temperature range
- **DNV / offshore** Certification
- **UL** approvals

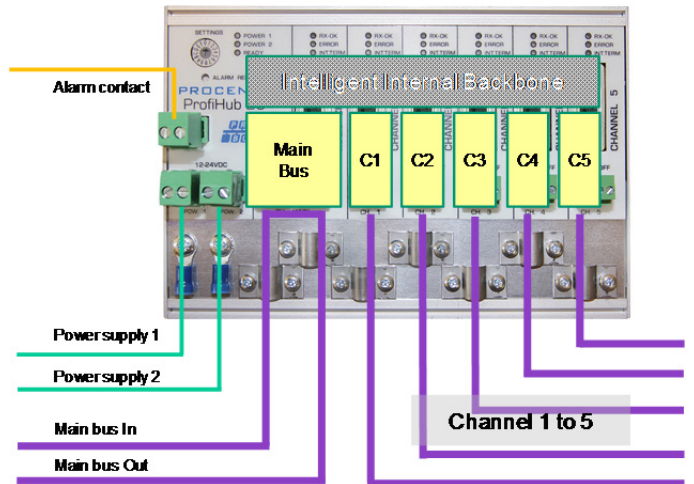

Fig. 2 - ProfiHub connections

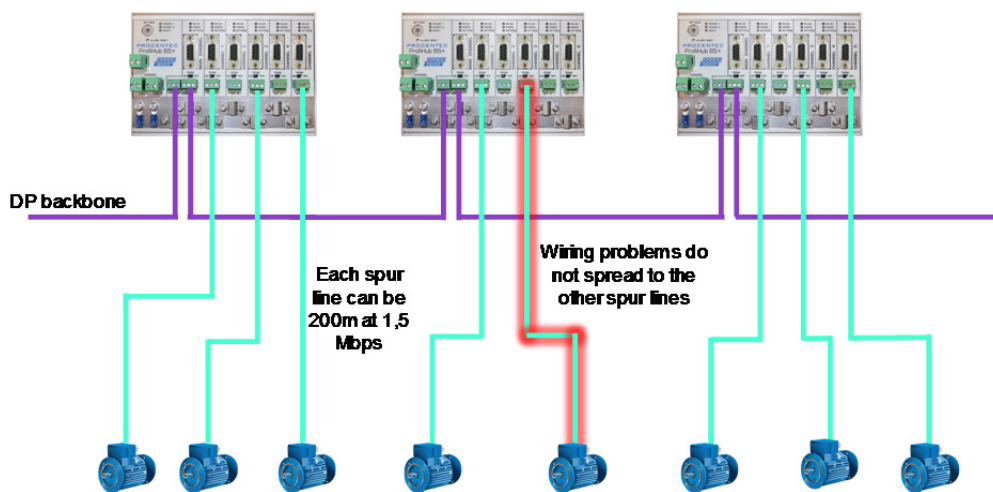

Fig. 3 - Long spur lines to instruments and the possibility to remove/insert them during operation. Short circuit protection on each spur line is automatically provided.



## 1.2 Application areas

- Dynamic spur lines to actuators, flow meters and pH analyzers.
- Removable drives and motors.
- Pull/Plug motor control centers (drawers).
- Roof mounted devices in tank farms.
- Barrier for non galvanic isolated equipment.
- Networks with requirement for High Availability/uptime
- Large star/tree structured networks.

## 1.3 Additional Benefits

- Hot slave **insertion and removal** during operation.
- **Short circuit protection** on each Channel.
- Option to create a **redundant path** to other Hubs or ComBricks
- Compact and robust construction.
- Status and error display (per Channel).
- Suitable for all DP cables.
- Conveniently arranged networks.
- Easy extendable installations.
- On-board DB9 female connector on each channel for maintenance activities.
- Cost Savings.

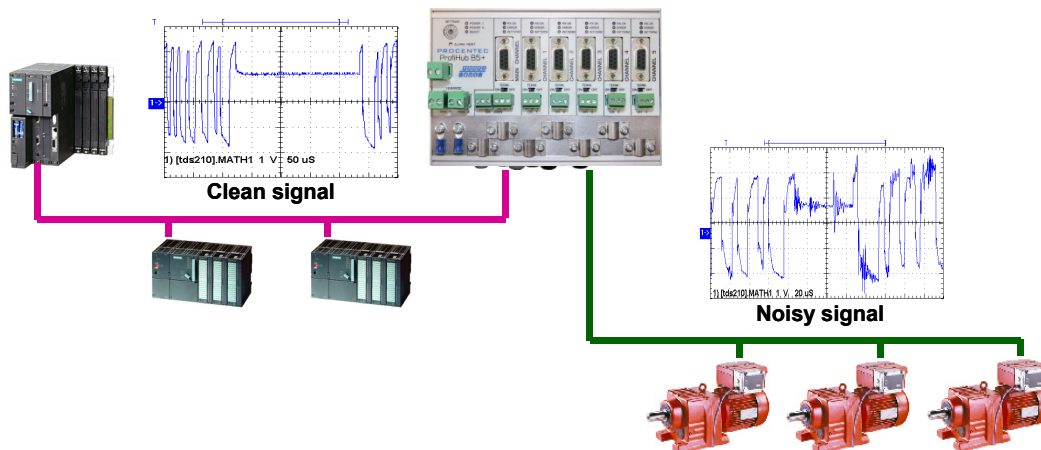

**Fig. 4 - Because of the isolation and intelligence the ProfiHub provides, it can be used as a barrier for electrically sensitive segments. This keeps the backbone and other Channels clean.**

## 1.4 Channel Structure

Each Channel is electrically isolated and internally connected to the transparent intelligent backbone. The termination is switchable and powered by the ProfiHub. The shielding of the PROFIBUS cable can be directly grounded or indirectly grounded (see the next paragraph).

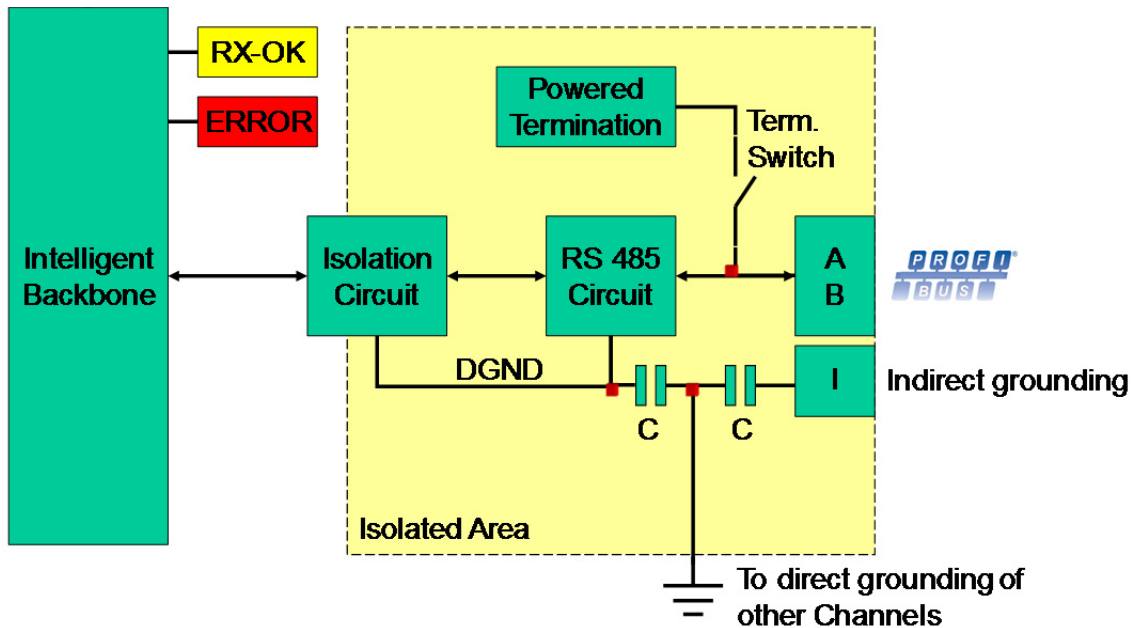

Fig. 5 - Channel structure

## 1.5 Grounding System

The ProfiHub B5+ can be grounded by 3 methods:

- 1) Direct grounding on the Ground Rail
- 2) Indirect grounding (through a capacitor)
- 3) Combination of direct and indirect.

The power supply must be grounded directly on the Ground Rail. The shielding of the PROFIBUS cables can be directly or indirectly grounded. If you do not want to ground all or some cables to the common ground, i.e. compensating current, the cable shielding must be connected to pin 'I' which stands for Indirect grounding. A capacitor with a parallel high value resistor will separate the 2 potentials (Fig. 5), ensuring protection of the signal against non-DC disturbances.

If by accident on 1 channel the Direct Grounding is connected with the Indirect Grounding, the connection to the Direct Grounding bypasses the capacitor in the Indirect Ground connection. The current on the shield will flow to Direct Ground.

## 1.6 Cable lengths for PROFIBUS DP

The cables on the Channels and the Main-Channel must comply with the PROFIBUS DP cable specifications for RS 485 (Fig. 6).

Baudrate (kbit/s)	9.6	19.2	45.45	93.75	187.5	500	1500	3000	6000	12000
Segment length (m)	1200	1200	1200	1200	1000	400	200	100	100	100
Segment length (feet)	3940	3940	3940	3940	3280	1310	656	328	328	328

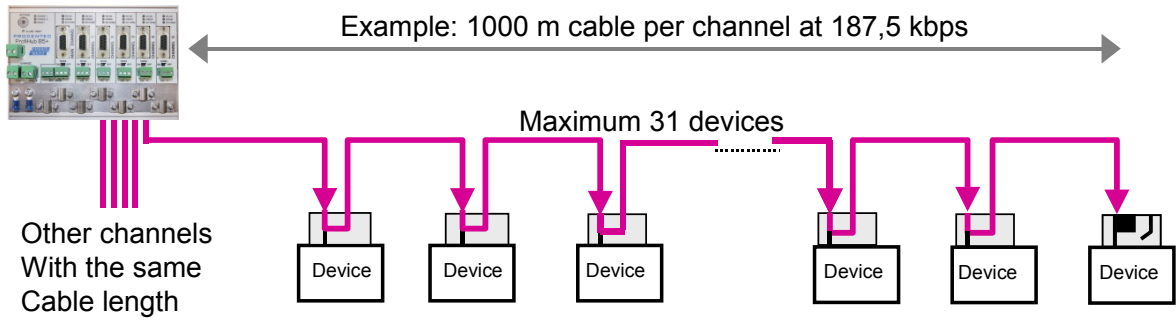

Fig. 6 - Cable lengths for PROFIBUS DP

## 1.7 Cable types for PROFIBUS DP

The cable type must comply with the PROFIBUS DP cable specifications for RS 485 (Fig. 7).

Parameter	Value
Wires	2 (twisted)
Impedance	135 .. 165 Ohm at 3 to 20 MHz
Capacity	< 30 pF/m
Loop resistance	< 110 Ohm/km
Wire diameter	> 0.64 mm
Wire area	> 0.32 mm <sup>2</sup>

Fig. 7 - PROFIBUS DP cable specifications

The ProfiHub B5+ can handle cables based on multiple protection sheaths with an overall cable diameter between 6 to 12 mm (Fig. 8).

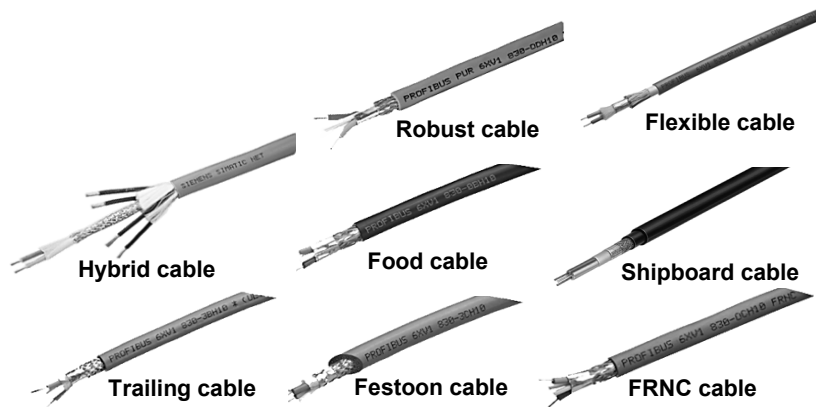



















Fig. 8 - Cables with different protection sheaths.

## 1.8 Status LEDs

The Status LEDs on the ProfiHub are very useful for diagnostics.

	OFF	Blinking	ON
<b>POWER 1 / 2</b>	 Power is not switched on or an internal failure.	 Power supply not stable, redundant power supply interrupted or an internal failure.	 Power supply OK.
<b>READY</b>	 Power is not switched on or an internal failure.	 Trying to detect the transmission speed, but has not locked it yet.	 The transmission speed has been detected.
<b>Main RX-OK</b>	 No communication detected on the Main-Channel.	 1 or more devices communicating on the Main-Channel.	 1 or more devices communicating on the Main-Channel.
<b>Main ERROR</b>	 No problem has been detected.	 Problem in the cabling has been detected (Main Channel).	 Problem in the cabling has been detected (Main Channel).
<b>Channel RX-OK</b>	 There is no communication detected (on this Channel).	 1 or more devices communicating (on this Channel).	 1 or more devices communicating (on this Channel).
<b>Channel ERROR</b>	 No problem has been detected.	 Problem in the cabling has been detected (on this Channel).	 Problem in the cabling has been detected (on this Channel).
<b>INT. TERM</b>	Termination for this channel is OFF.	Internal failure.	Termination for this channel is ON.

## 1.9 Comparison table

	ProfiHub A5	ProfiHub B5	ProfiHub B5+ / B5+RD
Area	IP 65	IP 20	IP 20
Redundant power supply	No	No	Yes
Temperature range	-20 to +60° Celcius	-20 to +60° Celcius	-25 to +70° Celcius
Housing	Plastic	Metal	Metal
Mounting	Corner screws	DIN-rail	DIN-rail
Weight	800 g	650 g	650 g
Dimensions	213 x 210 x 95 mm	167 x 111 x 32 mm	167 x 111 x 32 mm
PROFIBUS connectors	Screw terminals (inside) Glands (outside)	Screw terminals and DB9 connectors	Screw terminals and DB9 connectors
Alternative connectors	Glands can be replaced by M12 connectors	No	No
Termination LEDs	No	Yes	Yes
Ground rail	Optional	Yes	Yes
Redundant channel	No	No	Yes
Diagnostics Device	None	None	Yes, in B5+RD
Offshore approvals	None	None	Yes
UL approvals	None	None	Yes

## 2 Installation Instructions ProfiHub B5+

### 2.1 Location

The ProfiHub B5+ can be installed everywhere in a non-hazardous area that complies with IP 20 (DIN 40 050) and the specified temperature range of -25 to +70° Celsius.

### 2.2 Position

The ProfiHub B5+ can be installed in every position, but it is recommended to install it with the cables pointing down. In this position it is also easier to read the status LEDs.

### 2.3 Mounting

The ProfiHub B5+ can be mounted on 35 mm DIN-rail with a minimum width of 167 mm. Mounting brackets are available for mounting the B5+ directly on a wall. The ProfiHub B5+ has only been UL and DNV approved with 35 mm DIN-rail mounting!

The supplied rubber studs need to be placed on the back of the housing of the ProfiHub B5+ for extra fixation. This is to prevent the product to potentially slide off the DIN-rail. See **Fig. 9** for an example. When used in DNV environments these rubber studs need to be installed!



Fig. 9 – Rubber studs on backside of housing

## 2.4 Power Supply

To comply with UL certification regulations the power supply must be a Limited Power Source (LPS) or NEC Class 2 or CEC Class 2 that cannot exceed 100VA.

The two 2-pin screw type power connectors are located on the left of the ProfiHub B5+ (Fig. 10).  
 1 = + (left)  
 2 = - (right)

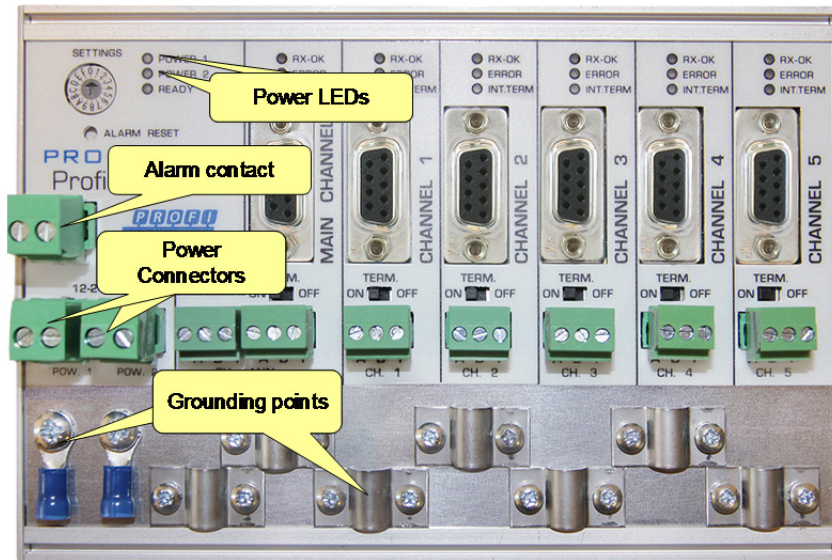

Fig. 10 - Power connectors and LEDs

Both power connectors are linked 1-on-1 to the internal power supply of the B5+. If one power supply fails, the other takes over without delay time. When redundancy is not required, it is sufficient to use one power connector. Please note that when using only one power supply, a voltage of max. 0.25 V will exist on the other unconnected power connector, as shown in Fig. 11.

If only one power supply is used, the alarm contact is closed. If two power sources are connected, the contact is open. As soon as one of the power supplies fails, the contact will close and the Power Indicator LED will blink.

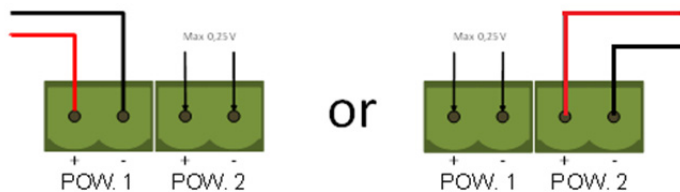

Fig. 11 – Maximum voltage on unconnected Power Connector

For UL certified installations the power supply must comply with the following specifications:

- Limited Power Source (LPS) or NEC Class 2 or CEC Class 2
- Voltage: **12 - 24 VDC**
- Current: **min 275 mA**
- Wire diameter: **< 2.5 mm<sup>2</sup>**



## Procedure

To connect the 24V supply to the 2-pin screw-type terminal, proceed as follows:

- Strip the insulation from the cable or the conductors for the 24V power supply.
- Add cable crimp terminals/wire ferrules to the conductors.
- Secure the crimp terminals in the screw-type terminal.

To connect the power supply, you need a 3 mm screwdriver.

## Testing

If the power is switched on it can be diagnosed by the following indicators:

- LEDs should be blinking in a circular animation for a short time.
- The POWER LED of the respective power connector (1, 2 or both) is ON.
- The READY LED is ON or Blinking, depending on baud rate lock.

## 2.5 Grounding of the power



It is recommended to use a power supply with a ground lead (3-wire). Connect the ground lead of the power lead to the Ground Rail of the ProfiHub B5+. Connect the Ground Rail to the common ground with a separate ground lead. See **Fig. 12** for an example.

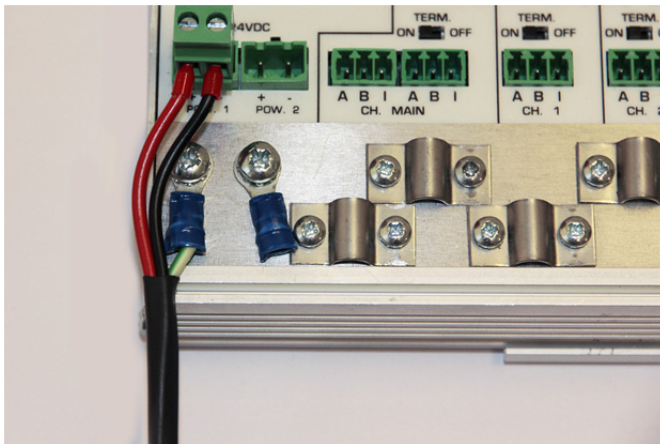

Fig. 12 - Connection to Ground Rail

## 2.6 Relay contact

The ProfiHub B5+ features a potential-free relay contact. This alarm contact can be used to monitor the power supplies. Example applications are: Connect a LED tower, alarm buzzer, SMS server or use it as a digital signal for the PLC. On the B5+RD version the relay can also be used for alarming in case of retires, illegals, or other events. For more information refer to **Chapter 3**.

If only one power supply is used, the alarm contact is closed after 60 seconds after start-up. If two power sources are connected, the contact is open. When one of the power supplies fails for 3 seconds or more, the contact will close and the Power Indicator LED will blink. If you are using only one power source and wish to use the Relay contact, simply connect Power 1 to Power 2.

In the case of an interrupted power supply you can reset the contact by pressing the 'Reset' button. The contact will open and the LEDs will stop blinking.

The Alarm contact is also switched when the ProfiHub is in Redundant mode and one of the redundant paths fails.

The maximum power to be connected to the alarm contact is 24 VDC. The maximum current consumption is 500 mA.

It is advised to use a Limited Power Source (LPS) of NEC Class 2 or CEC Class 2 for powering the alarm contact.

## 2.7 Backbone

Connect the DP backbone cable to the bottom-left connector of the Main-Channel (**Fig. 13**). If the ProfiHub is not the last device on the bus segment, connect the Bus-Out cable to the right connector of the Main-Channel (**Fig. 13**). The second method is to place a PROFIBUS standardized plug with an in/out cable on the DB9 connector.

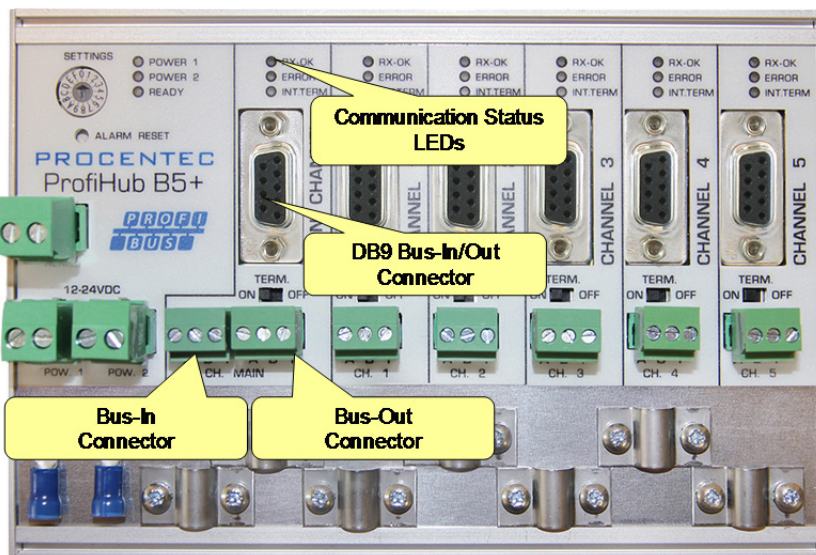

**Fig. 13 - PROFIBUS DP backbone connection**

Pin layout of the screw terminals:

- Pin "A": Green wire
- Pin "B": Red wire
- Pin "I": Indirect cable shielding

Note: Connecting the Indirect cable shielding is not required when the ground clips are used.

### Testing

- If the Main-Channel recognizes valid PROFIBUS messages from one or more connected devices, the RX-OK LED of the Main Channel should be blinking.

## 2.8 Spur Segments

Connect the spur segments to the connectors of Channel 1 to 5 (Fig. 14). The second method is to place a PROFIBUS standardized plug on the DB9 connector of the specific Channel.

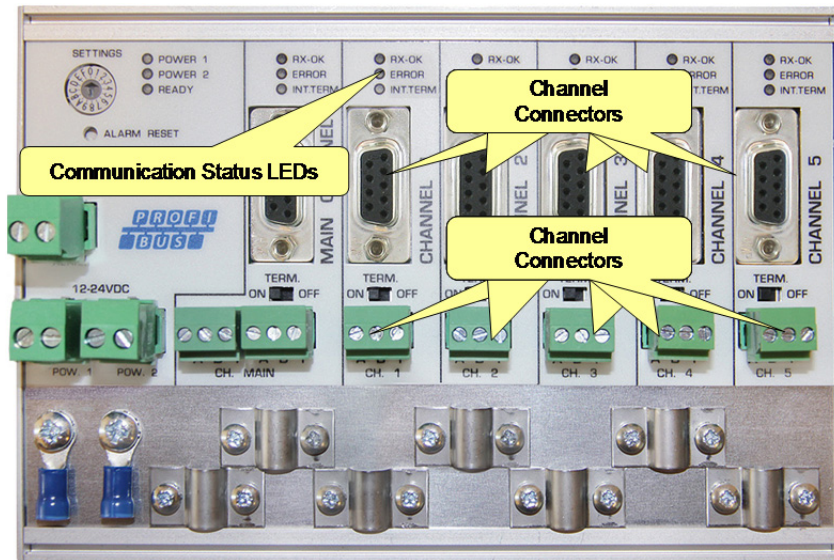

Fig. 14 - PROFIBUS DP spur connectors

### Pin layout of the screw terminals:

Pin "A": Green wire

Pin "B": Red wire

Pin "I": Indirect cable shielding

Note: Connecting the Indirect cable shielding is not required when the ground clips are used.

### Testing

- If a Channel recognizes valid PROFIBUS messages from one or more connected devices, the RX-OK LED of the Channel should be blinking.

According to UL60950-1, if a copper PROFIBUS cable is used outside, it is required to install surge protection that is suitable for PROFIBUS.

## 2.9 Termination

The termination of the Main-Channel has been set to OFF by default. If the ProfiHub is the last device on the segment, the termination must be set to ON (Fig. 15).

The termination of the Channels have been set to ON by default, because it is assumed that the new segment is started at the ProfiHub (Fig. 15).

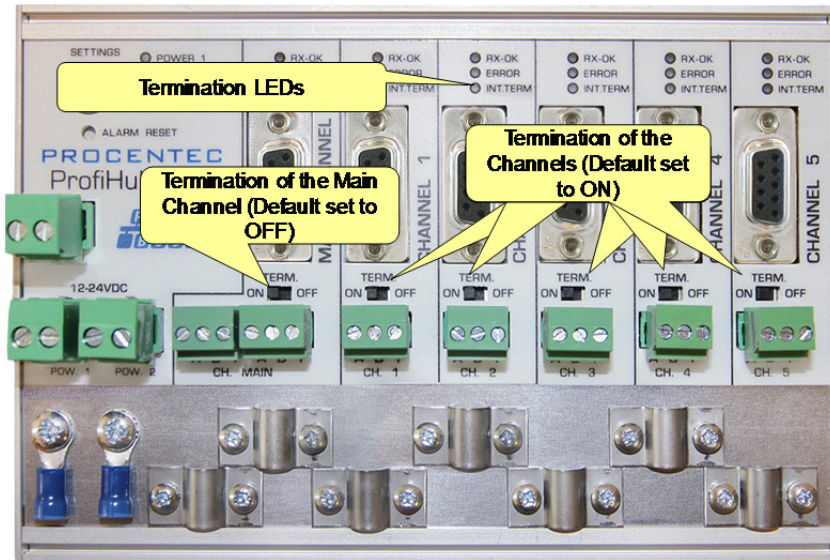

Fig. 15 - Termination Switches

The termination LED of the corresponding Channel is activated when the termination switch is set to ON.



When the DB9 connector is used and the cable starts at the ProfiHub, it is recommended to use the termination on the DB9 plug and NOT the ProfiHub. This way, the connector can be removed while maintaining termination on the bus.

## 2.10 Baudrate switch

The ProfiHub B5+ recognizes the transmission speed by default. If it is required that the ProfiHub B5+ is locked to a certain transmission speed, the baudrate switch should be set to the required value (Fig. 16).

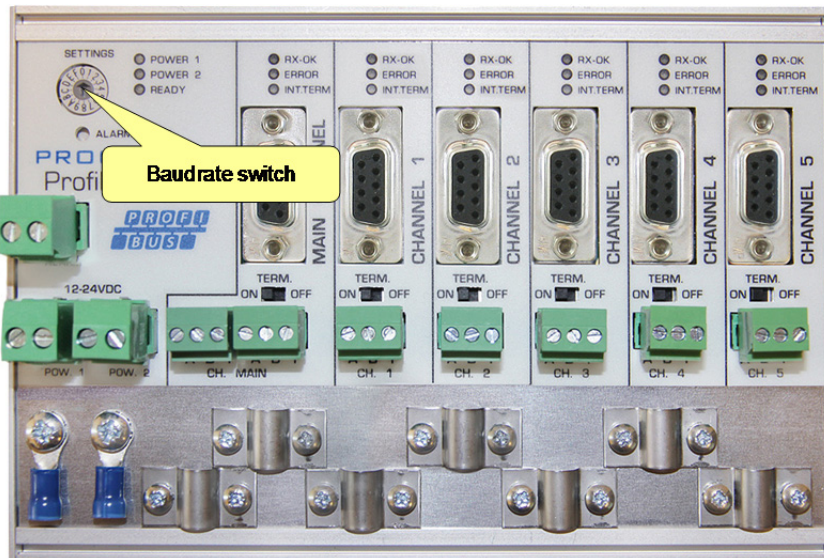

**Fig. 16 - Baudrate speed switch**

To set the rotary switch, use a 3 mm screwdriver.

### Switch values:

- 0 = Normal repeating, Auto baudrate detect (**default**)
- 1 = fixed 9.6 kbps, diagnostics device ON (B5+RD only)
- 2 = fixed 19.2 kbps, diagnostics device ON (B5+RD only)
- 3 = fixed 45.45 kbps, diagnostics device ON (B5+RD only)
- 4 = fixed 93.75 kbps, diagnostics device ON (B5+RD only)
- 5 = fixed 187.5 kbps, diagnostics device ON (B5+RD only)
- 6 = fixed 500 kbps, diagnostics device ON (B5+RD only)
- 7 = fixed 1500 kbps, diagnostics device ON (B5+RD only)
- 8 = fixed 3000 kbps, diagnostics device ON (B5+RD only)
- 9 = fixed 6000 kbps, diagnostics device ON (B5+RD only)
- A = fixed 12000 kbps, diagnostics device ON (B5+RD only)
- B = Robust repeating, Auto baudrate detect, diagnostics device ON (B5+RD only)
- C = Robust repeating, Auto baudrate detect, redundancy on channel 4 and 5, diagnostics device ON (B5+RD only)
- D = Normal repeating, Auto baudrate detect, diagnostics device ON (B5+RD only)
- E .. F = Reserved for future use

Please note that the position of the rotary switch is only sampled during start-up. Changing the position of the switch will not have effect during operation.

The auto baudrate detect feature will search for the correct baud rate within 10 seconds of receiving the first telegram. This baud rate lock will be lost after 50 seconds of incorrect or no message reception.

In robust repeating mode, only messages starting with a valid PROFIBUS start delimiter are repeated (SD1, SD2, SD3, SD4 and Short Acknowledge). In Normal mode, every bit is transferred immediately onto the other channels.

## 2.11 Channel Redundancy

To use the Redundancy option of the B5+, set the rotary switch to the 'C' position. This enables the last two channels (4 and 5) to be one redundant path to another B5+, to a redundant ComBricks, or to any other supporting product. See **Fig. 17** for an example.

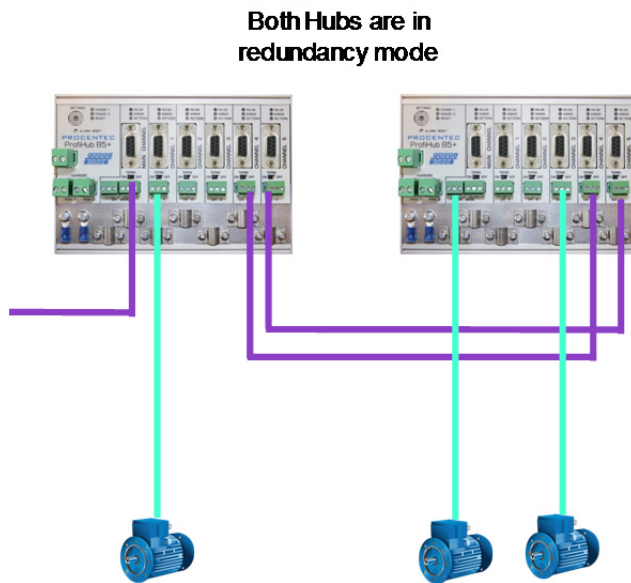

Fig. 17 - Redundant path between two ProfiHubs

The telegrams are transferred onto both redundant channels. The logic inside the ProfiHub determines which telegram is used to be transferred onto the other channels. A message received by a redundant channel is repeated on all other channels, except the other redundant channel. A message received by a normal channel is repeated on all other channels.

When one redundant cable breaks, the other cable ensures safe delivery of the telegram. In this event the built-in alarm contact will close. The red 'ERROR' LED will blink with an interval of 100ms. When the redundant path is fixed, press the 'ALARM RESET' pushbutton to reset the alarm.

### ATTENTION:

Using the ProfiHub B5+ in Redundancy mode causes a delay in processing the telegrams. When used together with ComBricks in redundancy mode it is required to increase the default MinTSDR in the PLC busparameters slightly. Recommended is to increase the MinTSDR with a value according to the Delay Time table, column 'Robust Mode', described in the Technical Data chapter.

## 3 Diagnostics Device

The B5+ is available with a built-in Diagnostics Device option. The order code for this ProfiHub B5 with diagnostics device is 17020RD.

The Diagnostics Device is a very versatile statistics/diagnostics logger. It can be used to keep track of the overall PROFIBUS network health and inform the PLC or DCS of any network failure such as repeats or illegals, missing ProfiHub termination, live list changes, or power supply problems. Audible or visible feedback is also possible by automatically switching the integrated alarm relay.

This information can also be read easily with ProfiTrace because the Diagnostic Device sends this data over PROFIBUS. This enables maintenance engineers to immediately identify the affected segment in case of cable problems or instrument failure. Having a Diagnostics Device in your network dramatically decreases downtime because problems can be solved much quicker; it tells you where to look. SCADA applications can make this even easier.

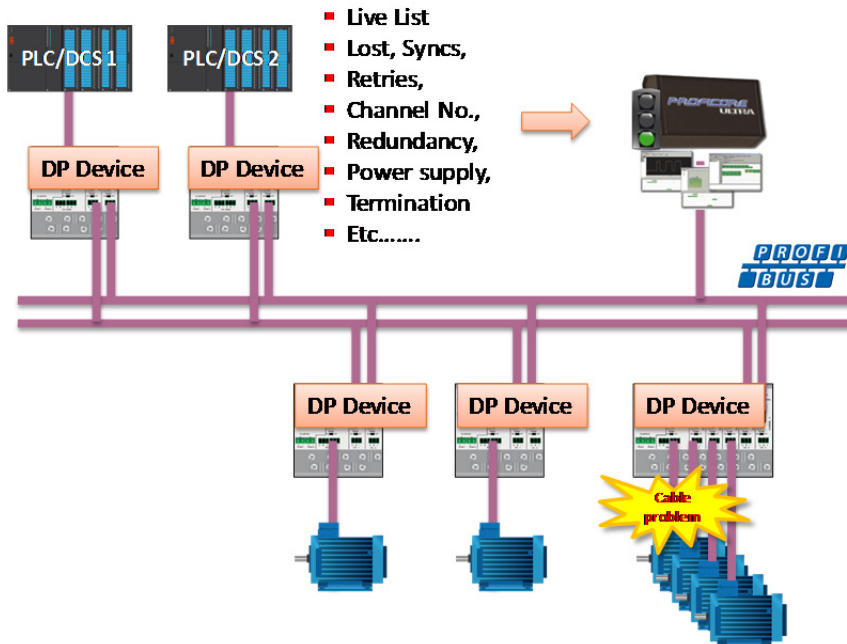

**Fig. 18 – Cable problems or node loss can be identified by the ProfiHub channel, and send this information over PROFIBUS to the PLC. ProfiTrace can also read this.**

The following statistics and events are continuously monitored:

Events:	Statistics:
Alarm Relay opened/closed	Losses
Cable Redundancy change	Syncs
Baudrate change	Repeats (total)
Power input changed	Repeats (max. changed in 1 cycle)
Termination of Channel changed	Illegals
Communication on Channel stopped/started	Internal Diagnostics
Livelist changed (station removed or added)	External Diagnostics
	Diagnostics while in Data Exchange

All of these events and statistics can be transferred in four different ways, so that the PLC/DCS or user can be warned that something is happening in the PROFIBUS network: a PROFIBUS input message, a diagnostic message, an external diagnostics message, or it can trigger the built-in alarm relay.

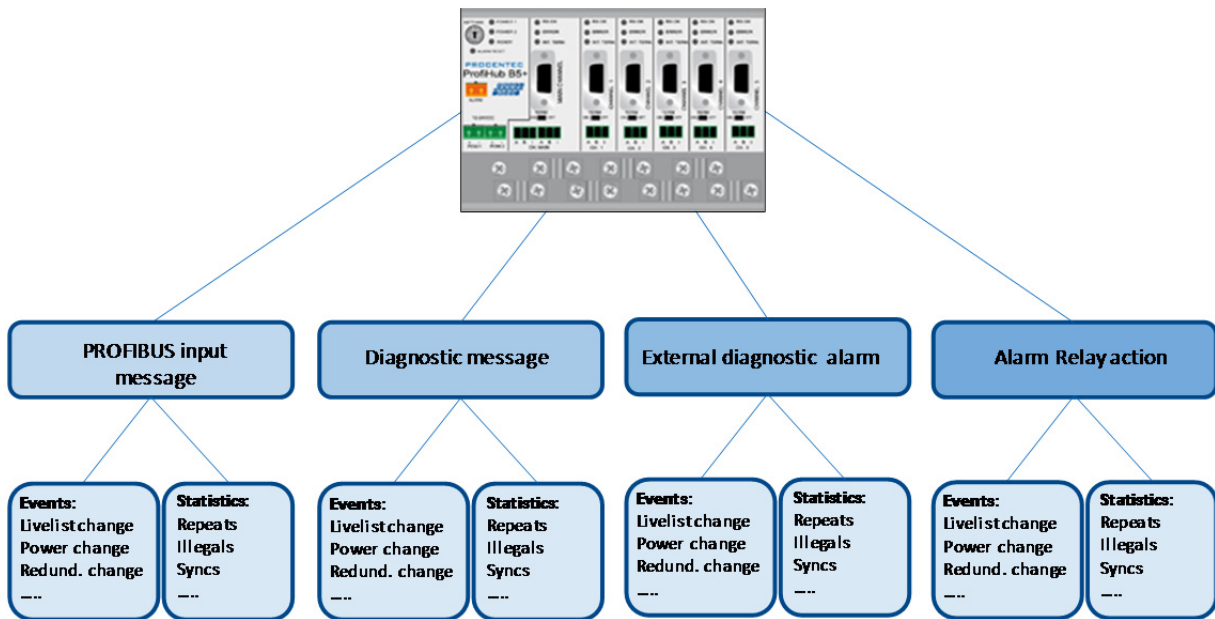

Fig. 19 - Ways of notifying the user in case of problems

## 3.1 Setting up the Diagnostics Device

### 3.1.1 Enabling the Diagnostics Device

To enable the Diagnostics Device in the ProfiHub, set the rotary switch on the top left side to any position from 1 to D (for a complete list of rotary switch settings, refer to the Technical Data chapter). Next, power-cycle the device by removing power and applying the power again. The rotary switch position is only read during start-up of the ProfiHub.

### 3.1.2 Changing the default PROFIBUS address

By default the address of the Diagnostic Device is set to 126. To change the address, use a configuration tool which supports the 'Set Slave Address' command. Most configuration tools support this feature.

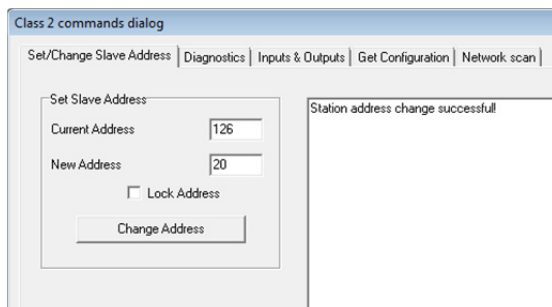

Fig. 20 - ProfiCaptain changes the address from 126 to 20



### 3.1.3 GSD file

Locate and download the appropriate GSD file for the Diagnostics Device on [www.procentec.com/downloads](http://www.procentec.com/downloads). The correct GSD file for the ProfiHub B5+RD is: **PROC6970.gsd**. The zip file also contains the corresponding .bmp (Bitmap) files. Import the GSD file into your configuration tool and insert the device in the PLC hardware configuration.



## 3.2 Configuring the Diagnostic Device

The Diagnostic Device has many configuration options. It can be configured modularly. This paragraph describes all the available options per module in list order.

### 3.2.1 Info data (mandatory module)

There is only one mandatory module, which is the first module in the list (“INFO DATA MANDATORY ON 1<sup>st</sup> SLOT”). It has 4 input bytes with the following meaning:

- Byte 1: Input Identifier byte (always 0xDE)
- Byte 2: Device type byte (0xB5 is ProfiHub B5+, 0xB2 is ProfiHub B2+)
- Byte 3: Version byte: 0x01
- Byte 4: Data format byte (0x00 is Little Endian, 0x01 is Big Endian)

### 3.2.2 Alarm Confirmation

Input Identifier byte: 0x01

The Alarm Confirmation module has one Output, which can be used to reset the alarm. If the Alarm Relay has been triggered by any event (see paragraph 2.6), it can be reset by the PLC by sending 0x01 or higher to the output of this module.

### 3.2.3 Redundant Status

Input Identifier byte: 0x10

The next input byte is to indicate the status of the redundant path. It is divided in nibble 0..3 and 4..7.

Nibble 1 (0..3)	Meaning
1 dec	Redundancy not used
2 dec	Redundancy error left channel
3 dec	Redundancy error right channel
4 dec	Redundancy error both channels
5 dec	Redundancy OK
Nibble 2 (4..7)	
1 dec	Pending Alarm: Redundancy error left channel
2 dec	Pending Alarm: Redundancy error right channel
3 dec	Pending Alarm: Redundancy error both channels

Examples: 0x12 means Redundancy error on Left Channel, Pending alarm on Left Channel  
 0x05 means Redundancy OK

### 3.2.4 Baudrate Status

Input Identifier byte: 0x11

The next input byte is to indicate the baudrate lock status.

Dec	Meaning
1	No baudrate detected
2	9.6 Kbit
3	19.2 Kbit
4	45.45 Kbit
5	93.75 Kbit
6	187.5 Kbit
7	500 Kbit
8	1.5 Mbit
9	3 Mbit
10	6 Mbit
11	12 Mbit

### 3.2.5 Relay Status

Input Identifier byte: 0x12

The next input byte is to indicate the alarm relay status.

Hex	Meaning
00	Relay is off
01	Relay is on

### 3.2.6 Power Status

Input Identifier byte: 0x13

The next input byte is to indicate the status of the power inputs.

Nibble 1 (bit 0..3)	Meaning
0	Power 1 is active
1	Power 2 is active
<b>Nibble 2 (bit 4..7)</b>	
4	Pending Alarm: Power 1 not active
5	Pending Alarm: Power 2 not active

Examples: 0x03: Power 1 and 2 are active  
 0x21: Power 1 is active, pending alarm: Power 2 not active  
 0x32: Power 2 is active, pending alarm: Power 1 and 2 not active (Relay should be reset in this case)

### 3.2.7 Termination Status

Input Identifier byte: 0x14

The next input byte is to indicate the status of the termination switches on the ProfiHub channels.

Bit	Meaning
0	Main Channel termination ON
1	Channel 1 termination ON
2	Channel 2 termination ON
3	Channel 3 termination ON
4	Channel 4 termination ON
5	Channel 5 termination ON

Examples: 0x3F = All terminations are ON  
 0x01 = Only Main Channel termination is ON  
 0x10 = Only Channel 4 termination is ON

### 3.2.8 Channel Status

Input Identifier byte: 0x15

The next input byte is to indicate the communication status of the individual channels.

Bit	Meaning
0	Communication on Main Channel
1	Communication on Channel 1
2	Communication on Channel 2
3	Communication on Channel 3
4	Communication on Channel 4
5	Communication on Channel 5

Examples: 0x08 = Communication on Channel 3  
 0x0A = Communication on Channels 1 and 3  
 0x2C = Communication on Channels 2, 3 and 5

### 3.2.9 Livelist Status

Input Identifier byte: 0x20

The next input byte is to indicate which Channel is selected to display the Livelist status.

Hex	Meaning
80	Livelist of Main Channel
81	Livelist of Channel 1
82	Livelist of Channel 2
83	Livelist of Channel 3
84	Livelist of Channel 4
85	Livelist of Channel 5
86	Livelist of this ProfiHub
FF	Livelist of all channels (entire network)

The next 32 input bytes are used for the actual Livelist data. Each address uses two bits. So the first two bits of the first byte are for address 0, the next two bits of the first byte are for address 1 and so on. The bits are used to indicate if the station is a slave device, master device or both.

Device:	Bit 1:	Bit 0:
None	0	0
Slave Device	0	1
Controller	1	0
Both	1	1

Example: If there is a master device on address 2, and a slave device on address 3, then the first byte will be 0x60, because it will look like this:

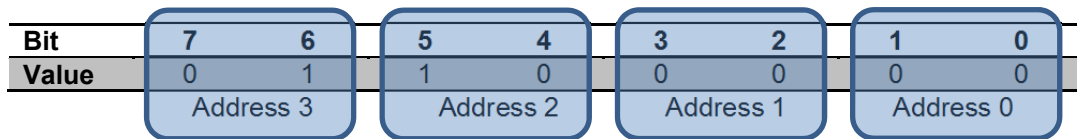

This module also has 2 Output bytes. The first Output byte is used to select the Livelist of a specific Channel. This selection can be read-back in the Input byte described above.

Hex	Meaning
80	Livelist of Main Channel
81	Livelist of Channel 1
82	Livelist of Channel 2
83	Livelist of Channel 3
84	Livelist of Channel 4
85	Livelist of Channel 5
86	Livelist of this ProfiHub
FF	Livelist of all channels (entire network)

The next Output byte can be used to reset the Livelist. Write 0x01 to this Output byte to reset the Livelist.

### 3.2.10 Statistics (Short Format, Long Format)

Input Identifier byte: 0x30 (short format) or 0x31 (Long Format)

The next byte is used to display the current selection of statistics that it sends.

Hex	Meaning
00..7E	Statistics for device 0..126
7F	Statistics for undefined devices
80	Statistics of Main Channel
81	Statistics of Channel 1
82	Statistics of Channel 2
83	Statistics of Channel 3
84	Statistics of Channel 4
85	Statistics of Channel 5
86	Statistics of this ProfiHub
FF	Statistics of all channels (entire network)

The next 16 bytes (Short Format) or 32 bytes (Long Format) are used to transfer the statistics of the selected address, selected Channel or all Channels of the ProfiHub. Each statistic uses 2 bytes (Short

Format, so a maximum of 65535 decimal per statistic) or 4 bytes (Long Format) and is sent in the following order:

1. Lost count
2. Sync count
3. Repeats total count
4. Repeats max per cycle count
5. Illegals count
6. Int. diagnostics count
7. Ext. diagnostics count
8. Diagnostics while in Data Exchange count

This module also has 2 output bytes. The first byte is used to configure the ProfiHub Statistics; you can choose which stations or Channels will display statistics. Configure it by sending the following output value:

Hex	Meaning
00..7E	Statistics for device 0..126
7F	Statistics for undefined devices
80	Statistics of Main Channel
81	Statistics of Channel 1
82	Statistics of Channel 2
83	Statistics of Channel 3
84	Statistics of Channel 4
85	Statistics of Channel 5
86	Statistics of this ProfiHub
FF	Statistics of all channels (entire network)

The next output byte can be used for clearing the statistics. Please note that the selected statistics of ALL node addresses and/or ProfiHub channels are cleared, not only for the displayed address or channel.

Bit	Meaning
0	Clear LOST statistics
1	Clear SYNC statistics
2	Clear REPEATS TOTAL statistics
3	Clear REPEATS MAX statistics
4	Clear ILLEGALS statistics
5	Clear INT. DIAG statistics
6	Clear EXT. DIAG statistics
7	Clear DIAG WHILE IN DX statistics

Example: To clear all LOST and ILLEGALS statistics, send 0x11  
 To clear all statistics, send 0xFF

### 3.3 Parameterizing the Diagnostic Device

The Diagnostic Device has many user-definable parameters that can be changed, to alter the behaviour and options of the ProfiHub Diagnostics Device.

#### 3.3.1 Diagnostics

The Diagnostics Device sends a diagnostic message on PROFIBUS whenever certain conditions are changed. These changes can be any of the following:

- Livelist change (a station added or removed)
- Bitrate error
- Alarm relay active
- Power status changed (one of the two power sources added or removed)
- Redundancy status change (one of the redundant cables added or removed)
- Termination status change (a termination switch on the ProfiHub has been changed)
- Channel status change (communication stopped or started on a channel)
- Statistics change (any statistic has changed)

In your configuration tool you can toggle the diagnostics for each item.

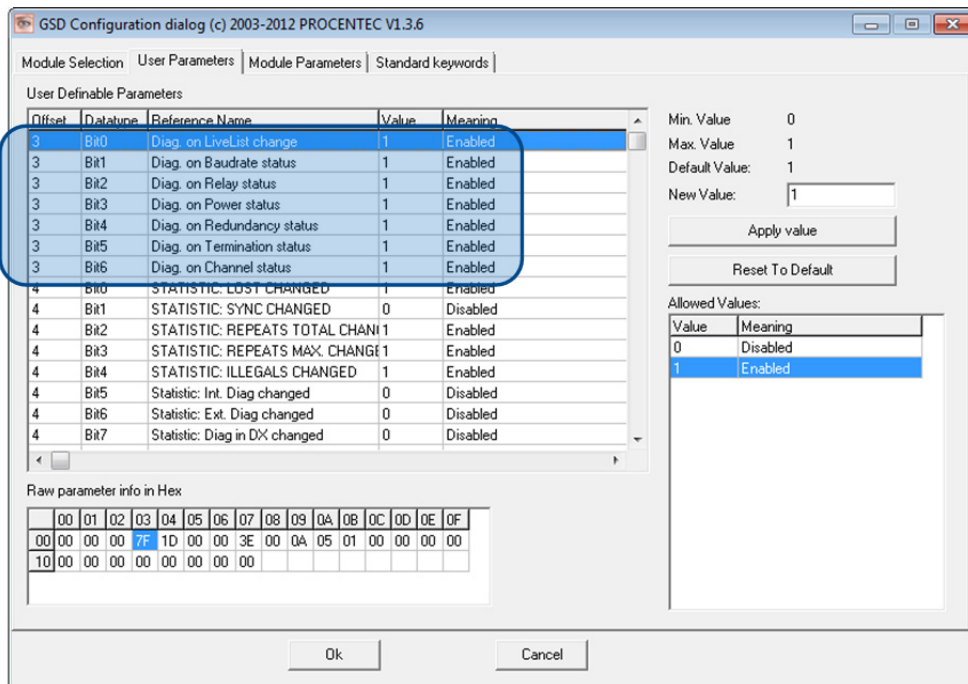

Fig. 21 - Screenshot of ProfiCaptain - User Parameter window

The 8<sup>th</sup> byte of a diagnostic message from the Diagnostic Device indicates which options have been enabled or disabled.

### 3.3.2 Statistics

You can choose which Statistics can trigger a diagnostic message, because not all statistics are interesting in all networks. For example, Syncs have been disabled by default because this is not a statistic that is suitable for PROFIBUS health monitoring.

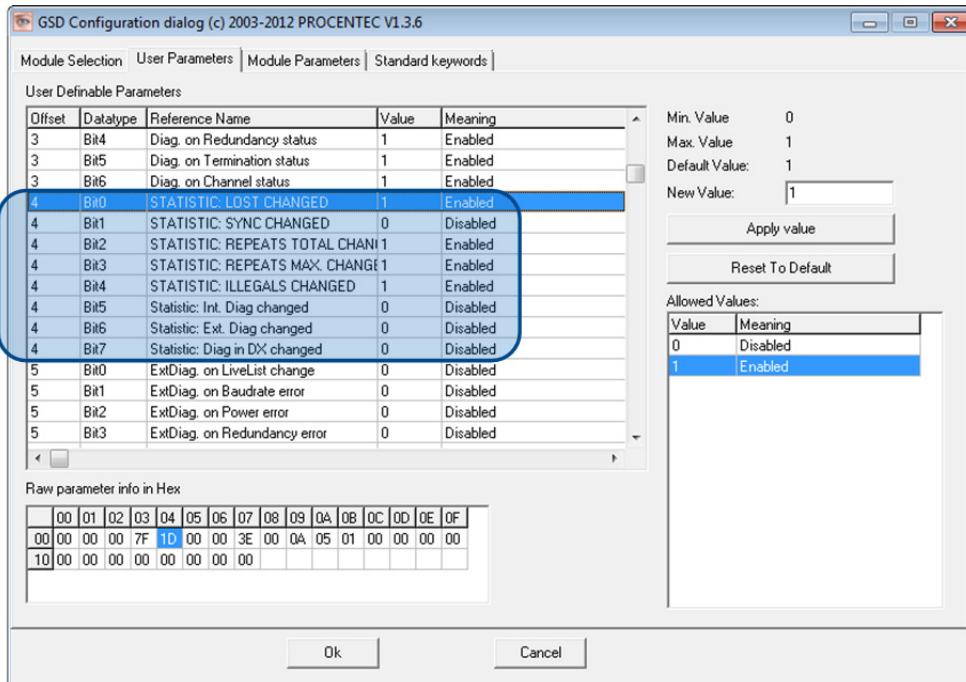

Fig. 22 – You can choose which statistics trigger a diagnostic message

The following Statistics can trigger a diagnostic message of the Diagnostic Device:

- Lost changed
- Sync changed
- Repeats (total) changed
- Repeats (max) changed
- Illegals changed
- Internal Diagnostics changed
- External Diagnostics changed
- Diagnostics in Data Exchange changed

### 3.3.3 Extended Diagnostics on Events change

For more critical applications you can choose to enable the 'Extended Diagnostics' option for each of the previously mentioned events. In the case of such an event, the Diagnostics Device will send out a diagnostics message with the 'Extended Diagnostic' bit on. In a Busmonitor tool such as ProfiTrace the extended diagnostics bit will appear as a red blinking square.

40	41
ProfiHub-B5+ Diagnostics	51
60	61

All Events described in **paragraph 3.3.1** can trigger the Extended Diagnostic bit of the Diagnostic Device. By default, the Extended Diagnostic option is disabled. Each item can be enabled individually.

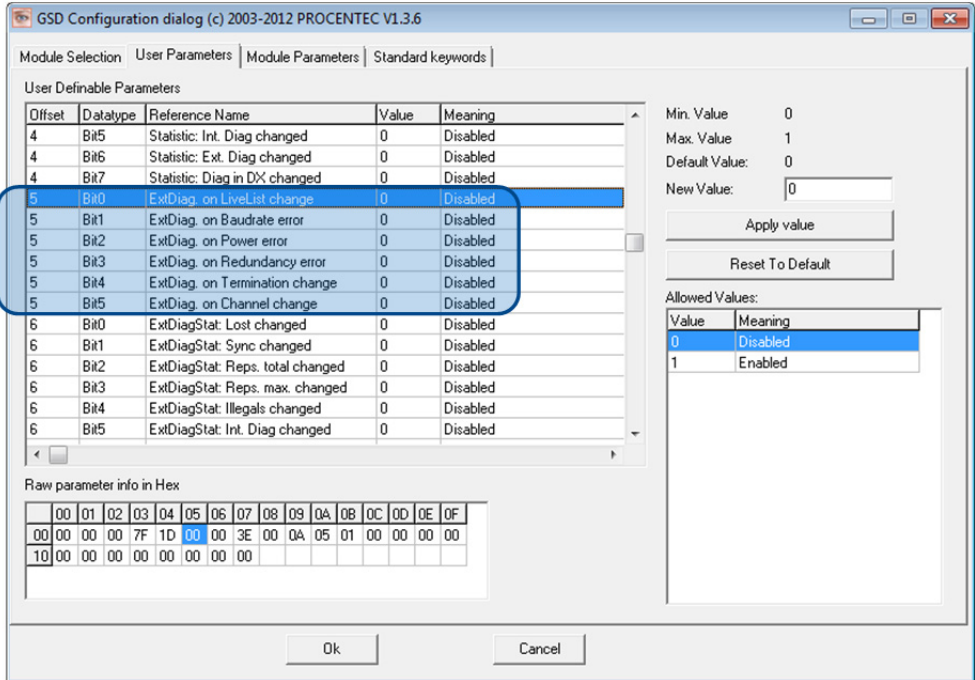

### 3.3.4 Extended Diagnostics on Statistics change

The Extended Diagnostic option can also be enabled for each individual available statistic. This works the same way as the Events described in **paragraph 3.3.3**.

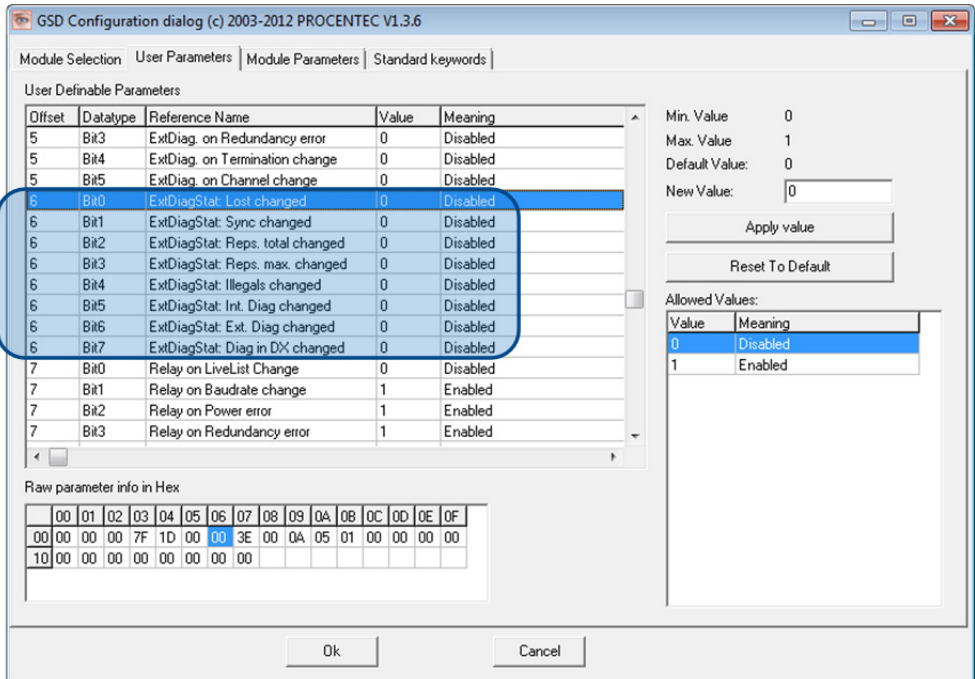



### 3.3.5 Alarm Relay on Events change

The Alarm Relay on the ProfiHub can be switched on each Event described in **paragraph 3.3.1**. When such an Event occurs, the Relay will be switched immediately without delay. The only Event that can delay the switching of the Alarm Relay is the Lost event. See **paragraph 3.3.8** for an explanation.

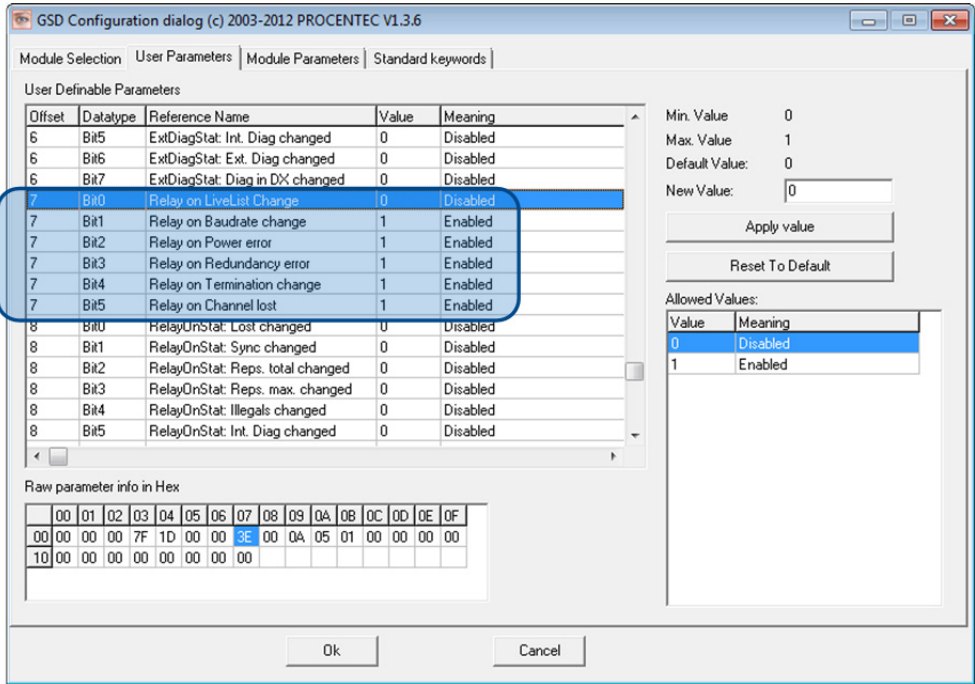

### 3.3.6 Alarm relay on Statistics change

The Alarm Relay on the ProfiHub can be switched (closed) on each change in Statistics, described in **paragraph 3.3.2**. When such an (enabled) Statistic change occurs, the Relay will be switched immediately without delay. The only Statistic that can delay the closing of the Alarm Relay is the Lost event. See **paragraph 3.3.8** for an explanation.

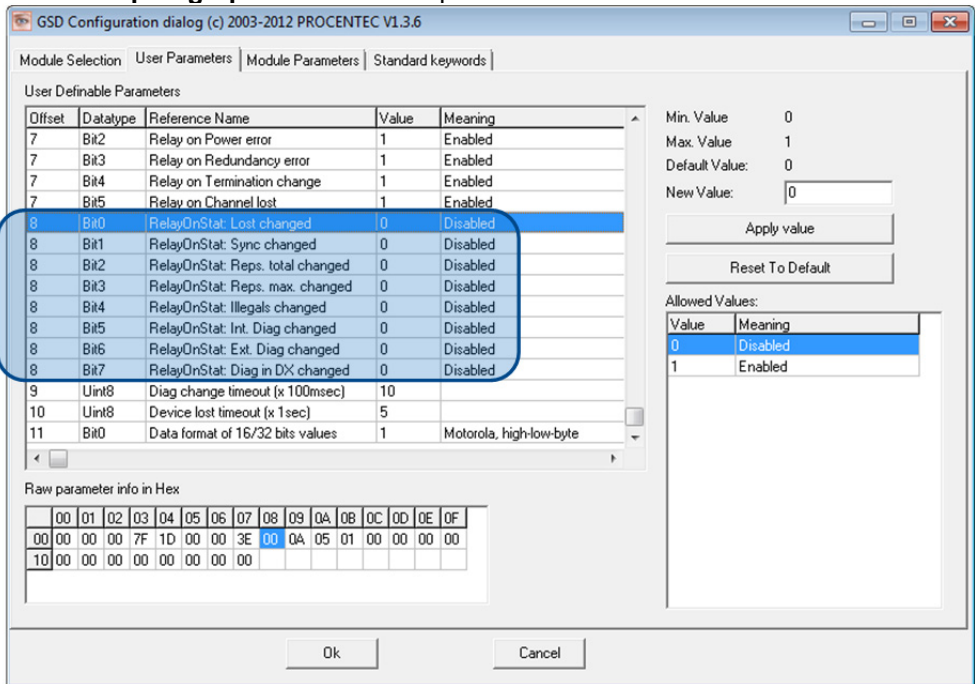

### 3.3.7 Changing the Diagnostics duration/timeout

You can change the duration of the Extended Diagnostics warning in steps of 100 milliseconds. The default value is 10, so 1 second. The maximum value is 255.

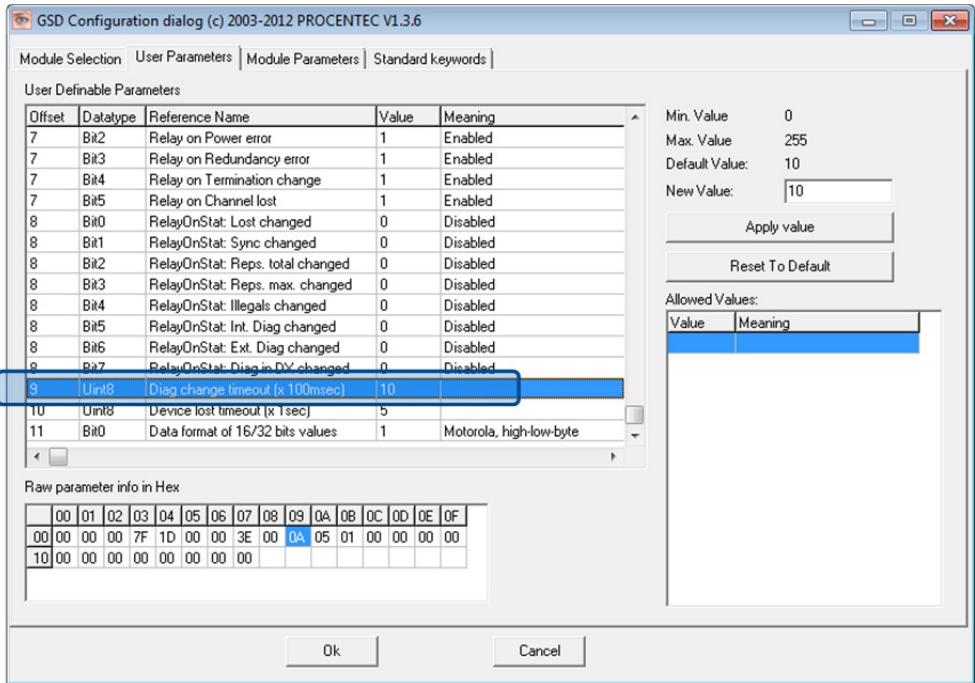

### 3.3.8 Changing the Device Lost timeout

The Diagnostics Device waits for a certain time before it considers a slave to be lost. This works in a similar way as the ProfiTrace Live List, where the background turns yellow when a slave stops communicating. This timeout can be changed in steps of 1 second. Default value is 5, and maximum value is 255.

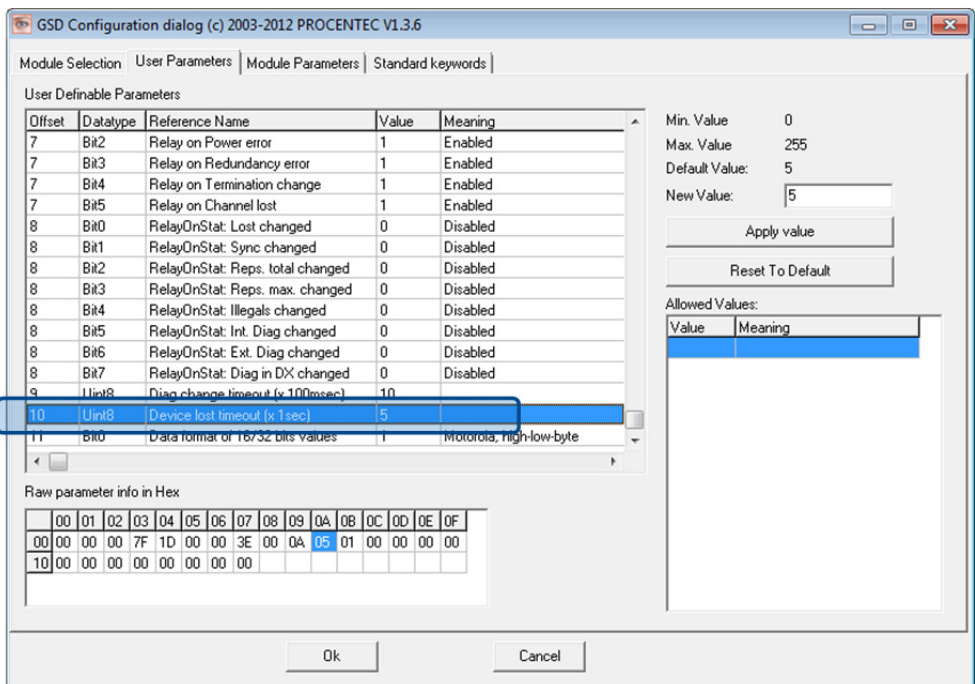

### 3.3.9 Changing the data format

The data format can be changed if needed. Default is Motorola, high-low-byte format. You can change it to Intel, low-high-byte format.

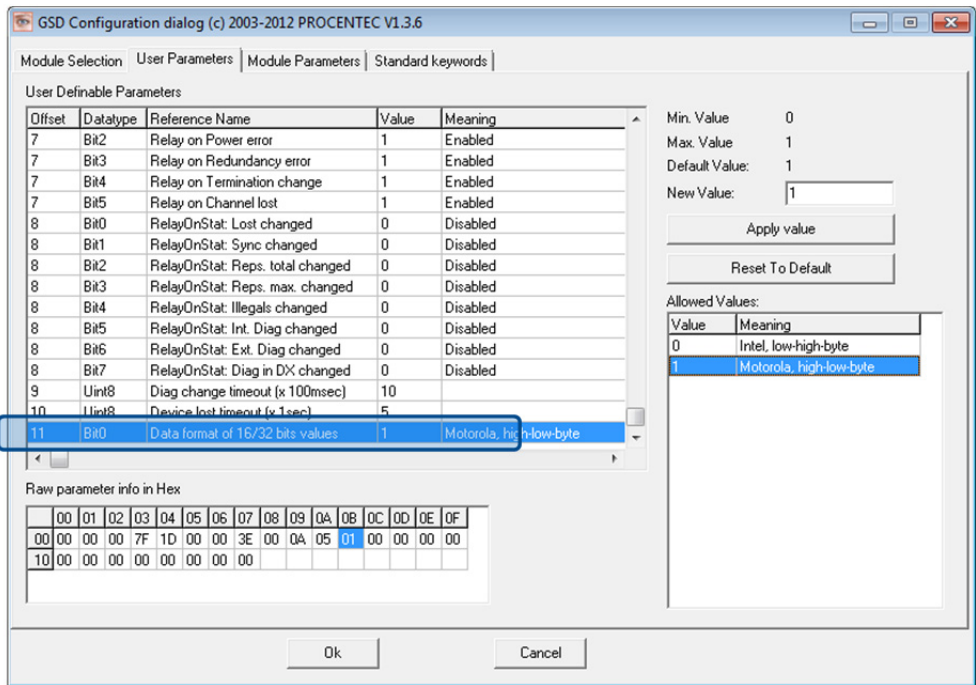

### 3.4 ProfiTrace plugin for the Diagnostic Device

On the download section of [www.procentec.com](http://www.procentec.com) you can download a useful plugin for the Diagnostic Device. It interprets all messages to and from the Diagnostic Device and displays the data in the Info Panel of ProfiTrace.

#### 3.4.1 Installing the Plugin

Once you have downloaded the file and extracted it to your hard drive, start ProfiTrace and choose 'Settings – Plugins' to bring up the Plugin window.

Click 'Install Plugin' and locate it on your harddrive. Next, click 'Enabled' so that ProfiTrace starts the plugin on startup.

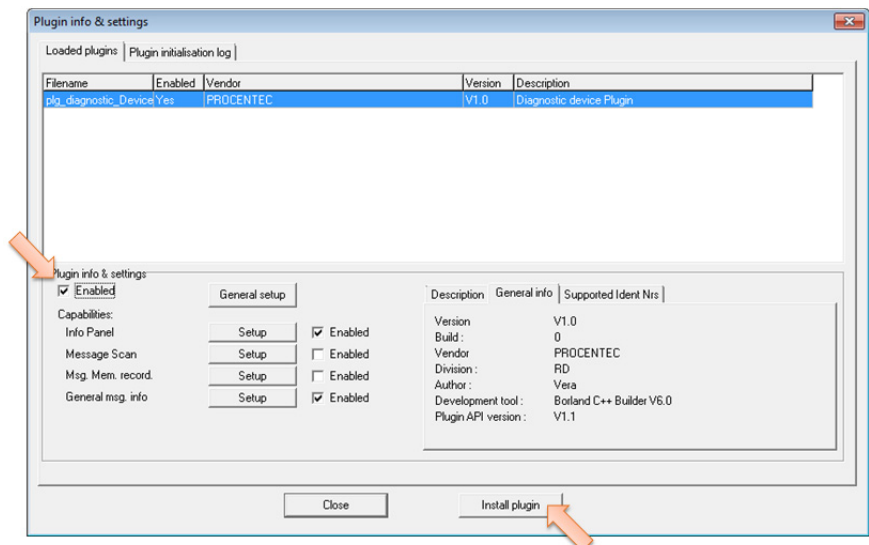

### 3.4.2 Using the Plugin

When the Plugin is correctly started and you have a ProfiHub with Diagnostics Device running, click 'Start Message Recording' in ProfiTrace, and view the screen with messages (see Fig. 23). If you click on a data exchange message to or from a Diagnostics Device, you will see all the interpreted data bytes in the Info Panel. This is very useful for Troubleshooting activities.

A good example is the Statistics. These statistics are available per individual channel or station address (see paragraph 3.2.10), so it is easy to see the source of the problem.

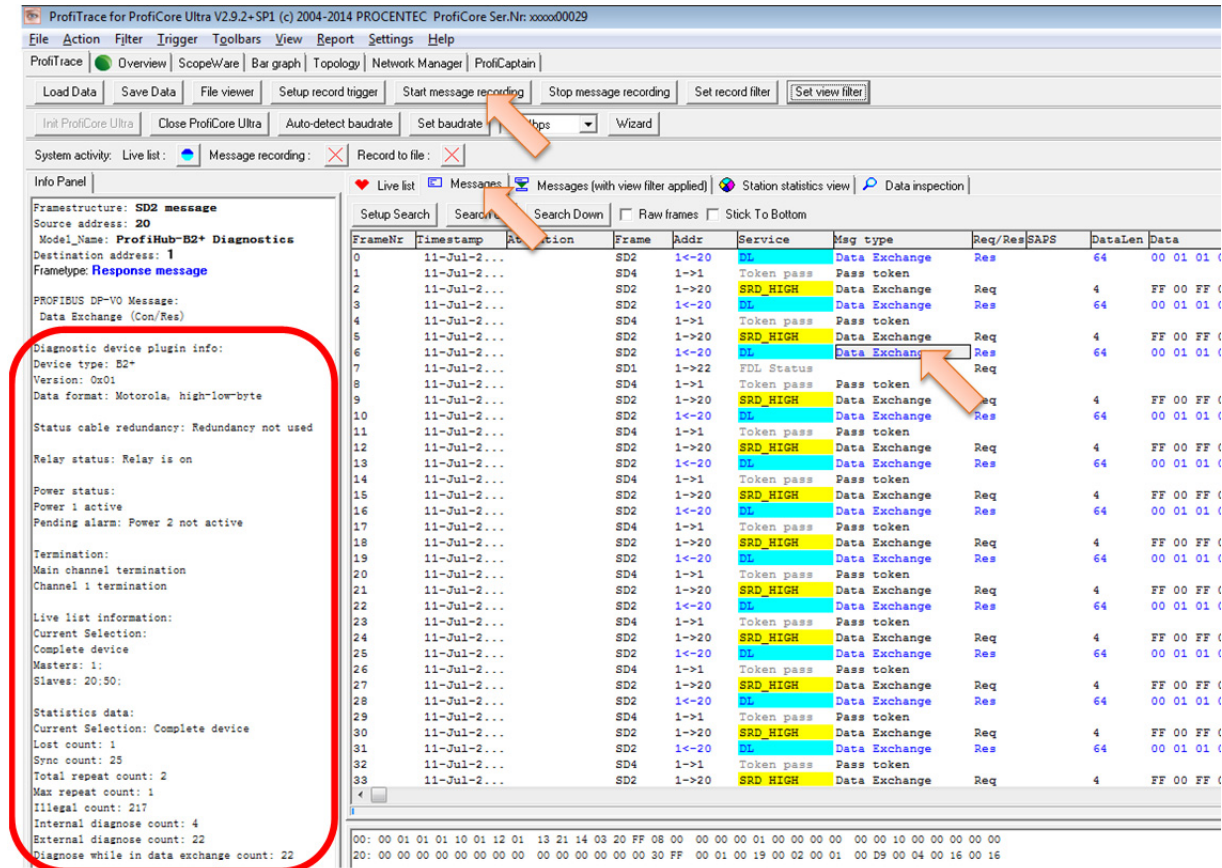

Fig. 23 - Info Panel with Profihub Diagnostics information

## 4 Technical Data ProfiHub B5+ / B5+RD

Technical Data ProfiHub B5+ and B5+RD																						
<b>Dimensions and weight</b>																						
Dimensions L x W x H (mm) with screws	167 x 111 x 32 mm																					
Weight	Approximately 650 g																					
<b>Ambient conditions</b>																						
Operating temperature	-25 to +70° Celsius -13 to +158° Fahrenheit																					
Isolation class	IP 20 (DIN 40 050)																					
<b>Protocol specifications</b>																						
Supported Protocols	DP-V0, DP- V1, DP-V2, FDL, MPI, FMS, PROFIsafe, PROFIdrive and any other FDL based protocol.																					
Transmission speed	9.6 kbps to 12 Mbps (including 45.45 kbps)																					
Transmission speed detection	Auto detect (default) or selectable with rotary switch																					
Transmission speed switch	<p><b>For position 1..D on B5+RD: Diagnostics Device ON</b></p> <p>0 = Normal repeating (Auto detect, diag off) (default)</p> <p>1 = 9.6 kbps</p> <p>2 = 19.2 kbps</p> <p>3 = 45.45 kbps</p> <p>4 = 93.75 kbps</p> <p>5 = 187.5 kbps</p> <p>6 = 500 kbps</p> <p>7 = 1500 kbps</p> <p>8 = 3000 kbps</p> <p>9 = 6000 kbps</p> <p>A = 12000 kbps</p> <p>B = Robust repeating (auto baudrate detect)</p> <p>C = Robust repeating, auto baudrate detect, redundancy on channel 4 and 5</p> <p>D = Normal repeating (auto baudrate detect)</p> <p>E .. F = Same as 0</p>																					
Transmission speed detection time	< 10 s (if it is set to auto detect)																					
Data delay time	<table style="width: 100%; border-collapse: collapse;"> <thead> <tr> <th style="text-align: left;">At baudrate:</th> <th style="text-align: left;">Normal mode:</th> <th style="text-align: left;">Robust mode:</th> </tr> </thead> <tbody> <tr> <td>9.6 - 93.75 kbps</td> <td>≤1.7 Tbit</td> <td>≤13.25 Tbit</td> </tr> <tr> <td>187.5 - 500 kbps</td> <td>≤1.8 Tbit</td> <td>≤13.30 Tbit</td> </tr> <tr> <td>1.5 Mbps</td> <td>≤1.9 Tbit</td> <td>≤13.40 Tbit</td> </tr> <tr> <td>3 Mbps</td> <td>≤2.2 Tbit</td> <td>≤13.60 Tbit</td> </tr> <tr> <td>6 Mbps</td> <td>≤3.0 Tbit</td> <td>≤14.00 Tbit</td> </tr> <tr> <td>12 Mbps</td> <td>≤4.0 Tbit</td> <td>≤15.00 Tbit</td> </tr> </tbody> </table>	At baudrate:	Normal mode:	Robust mode:	9.6 - 93.75 kbps	≤1.7 Tbit	≤13.25 Tbit	187.5 - 500 kbps	≤1.8 Tbit	≤13.30 Tbit	1.5 Mbps	≤1.9 Tbit	≤13.40 Tbit	3 Mbps	≤2.2 Tbit	≤13.60 Tbit	6 Mbps	≤3.0 Tbit	≤14.00 Tbit	12 Mbps	≤4.0 Tbit	≤15.00 Tbit
At baudrate:	Normal mode:	Robust mode:																				
9.6 - 93.75 kbps	≤1.7 Tbit	≤13.25 Tbit																				
187.5 - 500 kbps	≤1.8 Tbit	≤13.30 Tbit																				
1.5 Mbps	≤1.9 Tbit	≤13.40 Tbit																				
3 Mbps	≤2.2 Tbit	≤13.60 Tbit																				
6 Mbps	≤3.0 Tbit	≤14.00 Tbit																				
12 Mbps	≤4.0 Tbit	≤15.00 Tbit																				
Delay time jitter	Max. ¼ bit time																					

<b>Technical Data ProfiHub B5+ and B5+RD</b>	
<b>PROFIBUS Diagnostics Device specifications (only for B5+RD)</b>	
Supported protocol Ident Number GSD filename Bus address	DP-V0 6970 PROC6970.gsd 0-126 (software address only, set by software)
Transmission speed Transmission speed detection	9.6 kbps .. 12 Mbps (including 45.45 kbps) Auto Detect
Maximum transferrable data	85 bytes input and 5 bytes output
<b>PROFIBUS cable specifications</b>	
Cable lengths	1200 m at 9.6 kbps to 93.75 kbps 1000 m at 187.5 kbps 400 m at 500 kbps 200 m at 1.5 Mbps 100 m at 3 Mbps to 12 Mbps
Cable thickness Wire diameter Wire type	10 mm (when the ground rail is used) < 2.5 mm <sup>2</sup> Stranded or Solid core
Number of devices	Maximum 31 per Channel (including ProfiHubs, OLMs, Laptops/PCs, etc)
Termination	Integrated and switchable. Powered according to IEC 61158 (390/220/390 Ohms) - All Channels (default on) - Main-Channel (default off)
Cascading depth Redundancy	No limits Yes
<b>Power supply specifications</b>	
Power supply voltage Redundant power supply	9 to 31 VDC Yes
Current consumption Power dissipation	130 mA at 24 V power supply (all Channels fully loaded) Max. 4.1 W
Reverse polarity protection Cable thickness Wire diameter	Yes 10 mm (when the ground rail is used) < 2.5 mm <sup>2</sup>
<b>Alarm contact</b>	
Voltage Current	Max. 24 VDC 0.5 A
<b>Others</b>	
MTBF	398723 hours according to IEC-62380 (RDF2000/UTE C 80-180)

## Sales offices and Distributors

### HEADQUARTERS

PROCENTEC  
Klopperman 16  
2292 JD WATERINGEN  
Netherlands  
Tel.: +31-(0)174-671800  
Fax: +31-(0)174-671801  
Email: [info@procentec.com](mailto:info@procentec.com)  
Internet: [www.procentec.com](http://www.procentec.com)

### CHILE

RP Ingeniería Limitada  
Tucapel 92 oficina 52  
Concepción  
Chile  
Tel.: +56-(0)41-2469350  
Fax: +56-(0)41-2522592  
Email: [rodrigopinto@rpingeneria.cl](mailto:rodrigopinto@rpingeneria.cl)  
Internet: [www.rpingeneria.cl](http://www.rpingeneria.cl)

### GERMANY

PROCENTEC GmbH  
Benzstrasse 15  
D-76185 Karlsruhe  
Germany  
Tel.: +49-(0)721 831 6630  
Fax: +49-(0)721 831 66329  
Email: [info@procentec.de](mailto:info@procentec.de)  
Internet: [www.procentec.de](http://www.procentec.de)

### ARGENTINA

eFALCOM  
Alcorta 2411  
B1744- Moreno  
Buenos Aires  
ARGENTINA  
Tel.: +54 237 46 31 151  
Fax: +54 237 46 31 150  
Email: [santiago.falcomer@efalcom.com](mailto:santiago.falcomer@efalcom.com)  
Internet: [www.efalcom.com.ar](http://www.efalcom.com.ar)

### CHINA

PROCENTEC Beijing  
Room E-1115 WangJingYuan YouLeHui  
ChaoYang  
Beijing  
CHINA  
Tel.: +86(10)84766911 or 84787311  
Fax: +86(10)84766722  
Email: [info@procentec.net](mailto:info@procentec.net)  
Internet: [www.procentec.net](http://www.procentec.net)

### INDIA

U L ELECTRODEVICES P LTD  
NIRMAN CLASSIC ,  
KATRAJ-KONDHWA ROAD,  
KATRAJ, PUNE-411046  
India  
Tel.: +91-202 696 0050  
Fax: +91-202 696 2079  
Email: [dileep.miskin@ulepl.com](mailto:dileep.miskin@ulepl.com)  
Internet: [www.ulepl.com](http://www.ulepl.com)

### AUSTRALIA

IS Systems Pty Limited  
14 Laverick Ave., Tomago,  
NSW, Australia, 2322  
Tel.: +61 2 4964 8548  
Fax: +61 2 4964 8877  
Email: [fritz.woller@issystems.com.au](mailto:fritz.woller@issystems.com.au)  
Internet: [www.issystems.com.au](http://www.issystems.com.au)

### CZECH REPUBLIC

FOXON e-shop  
Polní 367  
460 01 Liberec 12  
Czech Republic  
Tel.: +420 484 845 555  
Fax: +420 484 845 556  
Email: [foxon@foxon.cz](mailto:foxon@foxon.cz)  
Internet: [www.foxon.cz](http://www.foxon.cz)

### IRELAND

PROFIBUS Ireland  
Automation Research Centre  
University of Limerick  
National Technology Park, Plassey  
LIMERICK, Ireland  
Tel.: +353-61-202107 or  
+35361240240  
Fax: +353-61-202582  
Email: [info@profibus.ie](mailto:info@profibus.ie)  
Internet: [www.profibus.ie](http://www.profibus.ie)

Pentair Flow Control Pacific  
Unit 4, 57 Pine Road, Yennora  
NSW, Australia, 2161  
Tel.: +61 2 9612 2323  
Fax: +61 2 9612 2324  
Email: [rkoenig@typac.com.au](mailto:rkoenig@typac.com.au)  
Internet: [www.profibuscentre.com.au](http://www.profibuscentre.com.au)

### DENMARK

ProSaiCon  
Jernbanegade 23B  
DK 4000 Roskilde  
Denmark  
Tel.: +45 70 20 52 01  
Fax: +45 70 20 52 02  
Email: [hj@prosaicon.dk](mailto:hj@prosaicon.dk)  
Internet: [www.prosaicon.dk](http://www.prosaicon.dk)

### ISRAEL

Instrumetrics Industrial Control  
8 Hamlacha St.  
New Industrial Zone  
Netanya, 42170  
Israel  
Tel.: +972-9-8357090  
Fax: +972-9-8350619  
Email: [info@instrumetrics-ic.co.il](mailto:info@instrumetrics-ic.co.il)  
Internet: [www.inst-ic.co.il](http://www.inst-ic.co.il)

### BELGIUM and LUXEMBOURG

Bintz Technics N.V.  
Brixtonlaan 25,  
1930 ZAVENTEM  
Belgium  
Tel.: +32 2 720 49 16  
Fax: +32 2 720 37 50  
Email: [bloemen@bintz.be](mailto:bloemen@bintz.be)  
Internet: [www.bintz.be](http://www.bintz.be)

### FINLAND

Hantekno Oy  
Kalliotie 2  
FIN-04360 Tuusula  
Finland  
Tel.: +358 40 8222 014  
Email: [info@hantekno.com](mailto:info@hantekno.com)  
Internet: [www.hantekno.fi](http://www.hantekno.fi)

### ITALY

C.S.M.T Gestione S.C.A.R.L.  
via Branze n. 43/45  
25123 BRESCIA  
Italy  
Tel.: +39 030 6595111  
Fax: +39 030 6595000  
Email: [profibus@csmt.it](mailto:profibus@csmt.it)  
Internet: [profibus.csmt.it](http://profibus.csmt.it)

### BRAZIL

Westcon Instrument. Indl Ltda  
Rual Alvaro Rodrigues, 257  
São Paulo – SP  
Brazil - CEP 04582-000  
Tel.: +55 11 5561-7488  
Fax: +55 11 5093-2592  
Email: [paolo@wii.com.br](mailto:paolo@wii.com.br)  
Internet: [www.wii.com.br](http://www.wii.com.br)

### FRANCE

AGILICOM  
Bâtiment B  
1, rue de la Briaudière  
Z.A. La Châtaigneraie  
37510 BALLAN-MIRE  
France  
Tel.: +33 247 76 10 20  
Fax: +33 247 37 95 54  
Email: [jj.bois@agilicom.fr](mailto:jj.bois@agilicom.fr)  
Internet: [www.agilicom.fr](http://www.agilicom.fr)

Genoa FIELDBUS Competence Centre  
Via Greto di Cornigliano, 6R/38  
16152 GENOVA  
Italy  
Tel.: +39 010 86 02 580  
Fax: +39 010 65 63 233  
Email: [procentec@gfcc.it](mailto:procentec@gfcc.it)  
Internet: [www.gfcc.it](http://www.gfcc.it)

<p><b>JAPAN</b></p> <p>TJ Group C/O Japanese PROFIBUS Organisation West World Building 4F 3-1-6 Higashi-Gotanda, Shinagawa-ku, TOKYO Japan Tel.: +81-3-6450-3739 Fax: +81-3-6450-3739 Email: info@profibus.jp</p>	<p><b>SAUDI ARABIA</b></p> <p>ASM Process Automation Al-Zahra Dist. – Atlas st. cross section with helmy Kutby St. Villa no.25 JEDDAH-21553 Tel.: +966 2 691 2741 Fax: +966 2 682 8943 Email: info@asmestablishment.com Internet: <a href="http://www.asmestablishment.com">www.asmestablishment.com</a></p>	<p><b>TAIWAN</b></p> <p>Full Data Technology 6F., No.200, Gangqian Rd., Neihu District, Taipei City 114, Taiwan Tel.: +886-2-87519941/9097 Fax: +886-2-87519533 Email: sales@fulldata.com.tw Internet: <a href="http://www.fulldata.com.tw">www.fulldata.com.tw</a></p>
<p><b>KOREA</b></p> <p>Hi-PRO Tech. Co., Ltd. #2802, U-Tower, 1029 Youngduk-dong, Giheung-gu Yongin-Si, Kyunggi-do, 446-908 KOREA Tel.: +82 82-31-216-2640 Fax: +82 82-31-216-2644 Email: chays@hiprotech.co.kr Internet: <a href="http://www.profibus.co.kr">www.profibus.co.kr</a></p>	<p><b>SINGAPORE</b></p> <p>Allegro Electronics 236 Serangoon Avenue 3 07-98 550236 Singapore Singapore</p> <p>ISEP (S) Pte Ltd Blk 3015A, #07-12, Ubi Road 1, Singapore 408705 Tel.: +65-6356 4237 Fax: +65-6844 4265 Email: <a href="mailto:stevenkee@ise-p.com">stevenkee@ise-p.com</a> Internet: <a href="http://www.ise-p.com">www.ise-p.com</a></p>	<p><b>TURKEY</b></p> <p>Emikon Otomasyon DES Sanayi sitesi 103 sokak B-7 blok No:16 Yukari Dudullu / Umraniye Istanbul 34776 Turkey Tel.: +90 216 420 8347 Fax: +90 216 420 8348 Email: <a href="mailto:tolgaturunz@emikonotomasyon.com">tolgaturunz@emikonotomasyon.com</a> Internet: <a href="http://www.emikonotomasyon.com">www.emikonotomasyon.com</a></p>
<p><b>LEBANON</b></p> <p>Industrial Technologies S.A.L (ITEC) Point Center, Boulevard Fouad Chehab, Sin El Fil BEIRUT Tel.: +961 1 491161 Fax: +961 1 491162 Email: sales@iteclb.com Internet: <a href="http://www.iteclb.com">www.iteclb.com</a></p>	<p><b>SLOVAKIA</b></p> <p>ControlSystem s.r.o. Stúrova 4 977 01 BREZNO Tel.: +421 486115900 Fax: +421 486111891 Email: <a href="mailto:jan.snopko@controlsystem.sk">jan.snopko@controlsystem.sk</a> Internet: <a href="http://www.controlsystem.sk">www.controlsystem.sk</a></p>	<p><b>UNITED ARAB EMIRATES</b></p> <p><b>Synergy Controls</b> 907, IT Plaza Silicon Oasis DUBAI UAE Tel.: +971 4 3262692 Fax: +971 4 3262693 Email: <a href="mailto:sales@synergycontrols.ae">sales@synergycontrols.ae</a></p>
<p><b>NETHERLANDS</b></p> <p>PROCENTEC B.V. Klopperman 16 2292 JD Wateringen Tel.: +31-(0)174-671800 Fax: +31-(0)174-671 801 Email: info@procentec.com Internet: <a href="http://www.procentec.com">www.procentec.com</a></p>	<p><b>SOUTH AFRICA</b></p> <p>IDX ONLINE CC 1 Weaver Street, Fourways JOHANNESBURG South Africa Tel.: +27(11) 548-9960 Fax: +27(11) 465-8890 Email: sales@idxonline.com Internet: <a href="http://www.idxonline.com">www.idxonline.com</a></p>	<p><b>UNITED KINGDOM</b></p> <p>Verwer Training &amp; Consultancy 5 Barclay Road Poynton, Stockport Cheshire SK12 1YY Tel.: +44 (0)1625 871199 Email: andy@verwertraining.com Internet: <a href="http://www.verwertraining.com">www.verwertraining.com</a></p>
<p><b>NORWAY</b></p> <p>AD Elektronikk AS Boks 641 N-1401 SKI Norway Tel.: +47 64 97 60 60 Fax: +47 64 97 60 70 Email: kai@ade.no Internet: <a href="http://www.ade.no">www.ade.no</a></p>	<p><b>SPAIN and PORTUGAL</b></p> <p>LOGITEK, S.A Ctra. de Sant Cugat, 63 Esc. B Planta 1ª Rubí (BARCELONA), 08191 Tel.: +34 93 588 67 67 Email: <a href="mailto:xavier.cardena@logitek.es">xavier.cardena@logitek.es</a> Internet: <a href="http://www.logitek.es">www.logitek.es</a></p>	<p>Hi-Port Software Limited The Hub 2 Martin Close Lee-on-Solent, Hampshire PO13 8LG  Tel.: +44 (0)8452 90 20 30 Fax: +44 (0)2392 552880 Email: sales@hiport.co.uk Internet: <a href="http://www.hiport.co.uk">www.hiport.co.uk</a></p>
<p><b>POLAND</b></p> <p>INTEX Sp. z o.o. ul. Portowa 4 44-102 GLIWICE Poland Tel.: +48 32 230 75 16 Fax: +48 32 230 75 17 Email: <a href="mailto:intex@intex.com.pl">intex@intex.com.pl</a> Internet: <a href="http://www.intex.com.pl">www.intex.com.pl</a></p>	<p><b>SWEDEN</b></p> <p>P&amp;L Nordic AB Box 252, S-281 23 HÄSSLEHOLM Sweden Tel.: +46 451 74 44 00 Fax: +46 451 89 833 Email: <a href="mailto:hans.maunsbach@pol.se">hans.maunsbach@pol.se</a> Internet: <a href="http://www.pol.se/profibus">www.pol.se/profibus</a></p>	<p>iTech Unit 1 Dukes Road Troon, Ayrshire KA10 6QR Tel.: +44 (0)1292 311 613 Fax: +44 (0)1292 311 578 Email: sales@itech-troon.co.uk Internet: <a href="http://www.itech-troon.co.uk">www.itech-troon.co.uk</a></p>
<p><b>ROMANIA</b></p> <p>S.C. SVT Electronics S.R.L. Brăila 7 540331 Tg-Mure Romania Tel.: +40 365 809 305 Fax: +40 365 809 305 Email: <a href="mailto:saigo.tibor@svt.ro">saigo.tibor@svt.ro</a> Internet: <a href="http://www.svt.ro">www.svt.ro</a></p>	<p><b>SWITZERLAND</b></p> <p>Berner Fachhochschule für Technik und Informatik PROFIBUS Kompetenzzentrum Jlcoweg 1 CH-3400 BURGDORF Switzerland Tel.: +41 (0) 34 426 68 32 Fax: +41 (0) 34 426 68 13 Email: <a href="mailto:max.felser@bfh.ch">max.felser@bfh.ch</a> Internet: <a href="http://www.profitrace.ch">www.profitrace.ch</a></p>	<p>Parkelect Ltd. 84 Dargan Road Belfast BT3 9JU N. Ireland Tel.: +44 2890 777743 Fax: +44 2890 777794 Email: <a href="mailto:gillan@parkelect.co.uk">gillan@parkelect.co.uk</a> Internet: <a href="http://www.parkelect.co.uk">www.parkelect.co.uk</a></p>





### UNITED STATES and MEXICO

Grid Connect Inc.  
1630 W. Diehl Road  
Naperville, Illinois 60563  
USA  
Tel.: +1 630 245-1445  
Fax: +1 630 245-1717  
Email: [sales@gridconnect.com](mailto:sales@gridconnect.com)  
Internet: [www.gridconnect.com/procentec.html](http://www.gridconnect.com/procentec.html)

### VIETNAM

Bavitech Corporation  
42 Truong Son Street  
Ward 2, Tan Binh District  
Ho Chi Minh City  
Tel.: +84-8-3547 0976  
Fax: +84-8-3547 0977  
Email: [hai.hoang@bavitech.com](mailto:hai.hoang@bavitech.com)  
Internet: [www.bavitech.com](http://www.bavitech.com)

## 5 Order codes

Component	Order code	Remarks
 <b>ProfiHub B5+</b>	17020	ProfiHub B5+ With Alarm contact With redundant power input
 <b>ProfiHub B5+R</b>	17020R	ProfiHub B5+ With Alarm contact With redundant power input With cable redundancy
 <b>ProfiHub B5+RD</b>	17020RD	ProfiHub B5+ with Diagnostics Device With Alarm contact With redundant power input With cable redundancy

## 6 Glossary

Address	Unique number of a device connected to the network. With PROFIBUS this can be 0 to 126. 127 is a broadcast address.
Analyzer	Software tool to observe the protocol traffic. Combi-Analyzers can also inspect the signal quality. Other term: Bus Monitor. Example: ProfiTrace.
Backbone	The primary bus cable. Most of the time only the control systems, ProfiHubs and fiber optic couplers are connected to this cable. The field devices are connected behind the ProfiHubs and fiber optic couplers.
Bit Time (Tbit)	The bit time Tbit is the time, which elapses during the transmission of one bit. It depends on the baudrate and is calculated as follows $Tbit = 1 \text{ (bit)} / \text{baudrate (bps)}$ . Examples: 12 Mbps --> Tbit = 83 ns 1.5 Mbps --> Tbit = 667 ns
Busparameters	Settings that define the timing behaviour on the bus. They are defined in the master. Examples: Tslot, MaxTSDR.
C	Capacitance.
DGND	Digital Ground.
DIN	German Institute for Standardization ( <a href="http://www.din.de">www.din.de</a> ).
DP-V0	DP-V0 is the basic stage of the PROFIBUS DP communication protocol. DP-V0 devices (master and slaves) perform the following basic functionalities: <ul style="list-style-type: none"> <li>- Cyclic exchange of I/O data between controlling and slave devices</li> <li>- Device, Identifier (module) and Channel related Diagnosis</li> <li>- Parameterization of DP-slaves</li> <li>- Configuration of DP-slaves</li> </ul>
DP-V1	DP-V1 is the first stage of extension of PROFIBUS DP after DP-V0. DP-V1 devices shall comply with the following features: <ul style="list-style-type: none"> <li>- Device related diagnosis is replaced by status and alarms.</li> <li>- The first three octets of the user parameterization data are now standardized</li> <li>- Optionally these devices may support: <ul style="list-style-type: none"> <li>- Acyclic communication (MS1, MS2)</li> <li>- If alarms are used, MS1 shall be supported</li> </ul> </li> </ul>

DP-V2	<p>DP-V2 is the second stage of extension of PROFIBUS DP after DP-V1. DP-V2 devices shall comply with the following features:</p> <ul style="list-style-type: none"> <li>- Data Exchange Broadcast (DxB) for slave to slave communication (publisher/subscriber principle).</li> <li>- Isochronous Mode (time tick synchronized operating slaves, e.g. drives)</li> <li>- Up- and/or download of Load Region Data (domains)</li> <li>- Clock Control (synchronization within slaves) and Time Stamping</li> <li>- Redundancy.</li> </ul>
Electromagnetic Compatibility	<p>See <i>EMC</i>.</p>
EMC	<p>The extent to which an electric or electronic device will tolerate electrical interference from other equipment (immunity), and will interfere with other equipment. Within the European Community as well as in other countries it is regulated by law that electric and electronic components and equipment comply with basic standards such as IEC 61000-6-2 or IEC 61326 or corresponding individual product standards.</p>
Hub	<p>A Hub refreshes a signal and passes the information on to all nodes which are connected to the Hub. Data frames which were received on one port are transferred to all the other ports (chicken foot topology).</p>
MPI	<p>Multiple Protocol Interface. Protocol defined by Siemens which uses the layer 1 and 2 of PROFIBUS (FDL).</p>
PCB	<p>Printed Circuit Board.</p>
PROFIBUS DP	<p>Acronym for "PROFIBUS for Decentralized Peripherals". Specification of an open fieldbus system with the following characteristics:</p> <ul style="list-style-type: none"> <li>- Polling master-slave-system (cyclic communications, MS0)</li> <li>- Flying masters with robin round token passing coordination (MM)</li> <li>- Connection based (MS1) and connectionless (MS2, MS3) acyclic communication between masters and slaves</li> </ul> <p>Options (e.g.):</p> <ul style="list-style-type: none"> <li>- Data exchange broadcast (DXB), i.e. slave to slaves communication</li> <li>- Isochronous mode of slaves</li> <li>- Clock synchronization</li> <li>- Redundancy</li> </ul> <p>PROFIBUS DP is standardized within IEC 61158 and IEC 61784, communication profile families 3/1 and 3/2</p> <p>The term "PROFIBUS DP" also is a synonym for the RS485 based deployments within factory automation.</p>
Repeater	<p>Active physical layer device that receives and retransmits all signals over a different port to increase the distance and number of devices for which signals can be correctly transferred for a given medium.</p>
Spur line	<p>A cable attached to a bus segment with a T-connection . Spurs are not recommended with PROFIBUS DP. They are prohibited with 12 Mbps and PROFIsafe operations. German term is "Stichleitung".</p>

Stub line	See <i>Spur line</i> .
Tbit	See <i>Bit Time</i> .
Termination	A (powered) resistor network at both ends of a segment to prevent reflections (with PROFIBUS DP the termination must be powered).
Topology	In a communications network, the pattern of interconnection between network nodes; e.g. bus, ring, star configuration.
PI	PROFIBUS International. The International PROFIBUS Organization based in Karlsruhe.
PNO	PROFIBUS Nutzer Organization. The German PROFIBUS Organization based in Karlsruhe.
Drop cable	See <i>Spur line</i> .
Reflection	Part of the original signal that is transmitted back along the cable. It corrupts the original signal.

## 7 Certificates

### CERTIFICATE OF COMPLIANCE

**Certificate Number** 20131219-E365044  
**Report Reference** E365044-A1-UL  
**Issue Date** 2013-DECEMBER-19

**Issued to:** PROCENTEC B V  
TURFSCHIPPER 41  
2292 JC WATERINGEN NETHERLANDS

**This is to certify that representative samples of** Information Technology Equipment Including Electrical Business Equipment  
HUB-ProfiHub B5+ series

Have been investigated by UL in accordance with the Standard(s) indicated on this Certificate.

**Standard(s) for Safety:** UL 60950-1, Information Technology Equipment - Safety - Part 1: General Requirements  
CSA C22.2 No. 60950-1-07, Information Technology Equipment - Safety - Part 1: General Requirements

**Additional Information:** See the UL Online Certifications Directory at [www.ul.com/database](http://www.ul.com/database) for additional information

Only those products bearing the UL Listing Mark for the US and Canada should be considered as being covered by UL's Listing and Follow-Up Service meeting the appropriate requirements for US and Canada.

The UL Listing Mark for the US and Canada generally includes: the UL in a circle symbol with "C" and

"US" identifiers: (UL) the word "LISTED"; a control number (may be alphanumeric) assigned by UL; and the product category name (product identifier) as indicated in the appropriate UL Directory.

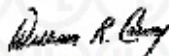

Look for the UL Listing Mark on the product.



William R. Casey, Director, North American Certification Programs  
UL LLC

Any information and documentation involving UL Mark services are provided on behalf of UL LLC (UL) or any authorized licensee of UL. For questions, please contact a local UL Customer Service Representative at [www.ul.com/contact](http://www.ul.com/contact)

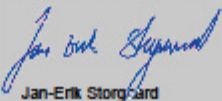

		Ref. Certif. No. <b>DK-36021-UL</b>
IEC SYSTEM FOR MUTUAL RECOGNITION OF TEST CERTIFICATES FOR ELECTRICAL EQUIPMENT (IECEE) CB SCHEME		SYSTEME CEI D'ACCEPTATION MUTUELLE DE CERTIFICATS D'ESSAIS DES EQUIPEMENTS ELECTRIQUES (IECEE) METHODE OC
<b>CB TEST CERTIFICATE</b> Product Produit  Name and address of the applicant Nom et adresse du demandeur  Name and address of the manufacturer Nom et adresse du fabricant  Name and address of the factory Nom et adresse de l'usine  <small>Note: When more than one factory, please report on page 2</small> <small>Note: Lorsque il y plus d'une usine, veuillez utiliser la 2<sup>ème</sup> page</small> Ratings and principal characteristics Valeurs nominales et caractéristiques principales  Trademark (if any) Marque de fabrique (si elle existe) Type of Manufacturer's Testing Laboratories used Type de programme du laboratoire d'essais constructeur  Model / Type Ref. Ref. De type  Additional Information (if necessary may also be reported on page 2) Les informations complémentaires (si nécessaire, peuvent être indiqués sur la 2 <sup>ème</sup> page  A sample of the product was tested and found to be in conformity with Un échantillon de ce produit a été essayé et a été considéré conforme à la  As shown in the Test Report Ref. No. which forms part of this Certificate Comme indiqué dans le Rapport d'essais numéro de référence qui constitue partie de ce Certificat	<b>CERTIFICAT D'ESSAI OC</b>  HUB  PROCENTEC B V TURFSCHIPPER 41 2292 JC WATERINGEN THE NETHERLANDS  PROCENTEC B V TURFSCHIPPER 41 2292 JC WATERINGEN THE NETHERLANDS  PROCENTEC B V TURFSCHIPPER 41 2292 JC WATERINGEN THE NETHERLANDS <input type="checkbox"/> Additional information on page 2 12-24 Vdc, 275 mA  Procentec  ProfiHub B5+ series  National Differences specified in the CB Test Report. <input type="checkbox"/> Additional information on page 2  IEC 60950-1(ed.2), IEC 60950-1(ed.2);am 1  E365044-A1-CB-1 issued on 2013-12-09	
This CB Test Certificate is issued by the National Certification Body Ce Certificat d'essai OC est établi par l'Organisme National de Certification		
	<input type="checkbox"/> UL (US), 333 Piquette Rd IL 60062, Northbrook, USA <input checked="" type="checkbox"/> UL (Denko), Borupvang 5A DK-2750 Ballerup, DENMARK <input type="checkbox"/> UL (JP), Marunouchi Trust Tower Main Building 8F, 1-8-3 Marunouchi, Chiyoda-ku, Tokyo 100-0005, JAPAN <input type="checkbox"/> UL (CA), 7 Underwriters Road, Toronto, M1R 3B4 Ontario, CANADA	For full legal entity names see <a href="http://www.ul.com/ulnames">www.ul.com/ulnames</a>
Date: 2013-12-09	Signature:  Jan-Erik Storgaard	



## DET NORSKE VERITAS

### TYPE APPROVAL CERTIFICATE

CERTIFICATE NO. **A-13659**

This is to certify that the  
**Peripheral Equipment**

with type designation(s)  
**ProfiHub B5+**

Issued to  
**Procentec**  
Wateringen, Netherlands

is found to comply with  
**Det Norske Veritas' Rules for Classification of Ships, High Speed & Light Craft and Det Norske Veritas' Offshore Standards**

Application  
Location classes:

Temperature	D
Humidity	B
Vibration	A
EMC	B
Enclosure	IP20 Required protection according to the Rules to be provided upon installation on board

This Certificate is valid until **2018-06-30**.

Issued at **Høvik** on **2014-02-11**

DNV local station: **Rotterdam, Product Certification /Verification**

Approval Engineer: **Andrzej Gdaniec**

for **Det Norske Veritas AS**  
Digitally Signed By: **Sneen, Ståle**  
Location: **DNV Høvik, Norway**  
Signing Date: **2014-02-13**

**Odd Magne Nesvåg**  
Head of Section

This Certificate is subject to terms and conditions overleaf. Any significant change in design or construction may render this Certificate invalid. The validity date relates to the Type Approval Certificate and not to the approval of equipment/systems installed. If any person suffers loss or damage which is proved to have been caused by any negligent act or omission of Det Norske Veritas, then Det Norske Veritas shall pay compensation to such person for his proved direct loss or damage. However, the compensation shall not exceed an amount equal to ten times the fee charged for the service in question, provided that the maximum compensation shall never exceed USD 2 million. In this provision "Det Norske Veritas" shall mean the Foundation Det Norske Veritas as well as all its subsidiaries, directors, officers, employees, agents and any other acting on behalf of Det Norske Veritas.



Certificate No.: A-13659  
 File No.: 899.60  
 Job Id.: 282.1-013420-1

### Product description

The ProfiHub B5+ is a network component for PROFIBUS DP installations, to implement long multi-device spur lines and backbone structures with star/tree segments.

The ProfiHub B5+ refreshes a received message on one channel and transfers it to all the other channels.

More details can be found in Procentec User Manual ProfiHub B5+ Ver.1.3.

### Approval conditions

The Type Approval covers hardware listed under Product description. When the hardware is used in applications to be classed by DNV, documentation for the actual application is to be submitted for approval by the manufacturer of the application system in each case. Reference is made to DNV Rules for Ships Pt.4 Ch.9 Control and Monitoring Systems.

#### Product certificate

If specified in the Rules, ref. Pt.4 Ch.9 Sec.1, the control and monitoring system in which the above listed hardware is used shall be delivered with a product certificate. For each such delivery the certification test is to be performed at the manufacturer of the application system before the system is shipped to the yard. The test shall be done according to an approved test program.

After the certification the clause for application software control will be put into force.

#### Clause for application software control

All changes in software are to be recorded as long as the system is in use on board. The records of all changes are to be forwarded to DNV for evaluation and approval. Major changes in the software are to be approved before being installed in the computer.

### Type Approval documentation

#### Manuals and drawings:

- ProfiHub B5+ User Manual, Ver.1.3, dated 2013-12

#### Test reports:

- DEKRA Test report No. 2164967.0502-EMC, dated 2013-09-19
- DEKRA Certificate Electromagnetic Compatibility No. 2164967.0551-EMC, dated 2013-09-19
- DEKRA Test report No. 2164967.0501-EMC, dated 2013-09-19
- DEKRA Attestation No. 2164967.0552-EMC, dated 2013-09-19

### Tests carried out

Applicable tests according to Standard for Certification No. 2.4, April 2006.

The 'Compass safe distance' was not measured according to section 11.2 of IEC 60945 4<sup>th</sup> edition (2002).

### Marking of product

Brand name: Procentec

Model name and part number: ProfiHub B5+

Serial number: Unique for each delivered item

### Periodical assessment

The scope of the periodical assessment is to verify that the conditions stipulated for the type are complied with, and that no alterations are made to the product design or choice of systems, software versions, components and/or materials.

The main elements of the assessment are:

- Ensure that type approved documentation is available
- Inspection of factory samples, selected at random from the production line (where practicable)
- Review of production and inspection routines, including test records from product sample tests and control routines
- Ensuring that systems, software versions, components and/or materials used comply with type approved documents and/or referenced system, software, component and material specifications
- Review of possible changes in design of systems, software versions, components, materials and/or performance, and make sure that such changes do not affect the type approval given
- Ensuring traceability between manufacturer's product type marking and the type approval certificate

Periodical assessment is to be performed at least every second year and at renewal of this certificate.

END OF CERTIFICATE

# certificate



QualityMasters hereby declares that

**Procentec B.V.**  
Wateringen



has a management system that meets the requirements of the standard

**NEN-EN-ISO 9001:2008**

for the scope

Providing training courses, technical support, product development and the exploitation of the test laboratory.

Date of original approval	10-02-2003
Date of issue	10-04-2013
Valid until	10-02-2016
Certificate number	NL 6313uk

On behalf of Stichting QualityMasters,

N.B. The failure to meet the conditions as set forth in the certification agreement, or non-compliance with the given standard and/or guidelines, may lead to the suspension or cancellation of the certificate. This certificate remains the property of Stichting QualityMasters, Nieuwland Parc 157, 3351 LJ Papendrecht.





## Certificate for a PI Competence Center

PI confirms that

**PROCENTEC**  
**Klopperman 16**  
**2292 JD Wateringen**  
**THE NETHERLANDS**

is a fully accredited PI Competence Center for  
PROFIBUS basic and PROFIBUS PA.

This certificate is granted according to the Quality of Services Agreement for  
PI Competence Centers and is valid for 2 years, until December 31, 2015.

(Official in Charge)

Chairmen of PI

(Karsten Schneider, Chairman)

(Michael J. Bryant, Deputy Chairman)





## Certificate

### Authorization as PI Test Laboratory for PROFIBUS

PROFIBUS Nutzerorganisation e.V. accepts  
**PROCENTEC**  
**Turfschipper 41**  
**2292 JC Wateringen**  
**The Netherlands**

as authorized PI Test Laboratory for:

### PROFIBUS Slave Devices PA Profile Devices

The authorization is based on the assessment dated March 20, 2013, and the related assessment report.

The execution of the tests aimed in the PROFIBUS certification shall be conform to the PROFIBUS Standard and the valid guidelines.

This authorization is valid until December 31, 2014.



(Official in Charge)

Board of PROFIBUS Nutzerorganisation e. V.

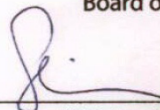

(K. Schneider)

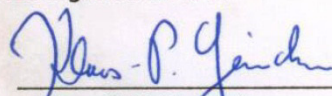

(K.-P. Lindner)



## 8 Revision History

### Version 1.0

- First release (B5+)

### Version 1.5

- Added the UL and DNV certificates
- Updated the Distributors chapter

### Version 2.0

- Added chapter 'Diagnostics Device'
- Textual changes in all chapters to adapt to B5+RD

### Version 2.1.0

- Textual changes





## Other PROCENTEC products

### IP 66 Compact PROFIBUS repeater

- ✓ Single channel PROFIBUS repeater
- ✓ Robust Repeating; reduces errors
- ✓ IP 66
- ✓ Transparent
- ✓ Max. 12 Mbps
- ✓ Auto baudrate detection
- ✓ Digital glitch filtering
- ✓ No limit in cascading
- ✓ On-board switchable termination
- ✓ Diagnostic LEDs
- ✓ M12 connector for measurements



### Compact PROFIBUS Repeater

- ✓ Single channel PROFIBUS repeater.
- ✓ Transparent.
- ✓ Latest RS 485 technology.
- ✓ Max. 12 Mbps.
- ✓ Auto baudrate detection.
- ✓ Redundant power supply.
- ✓ Digital glitch filtering.
- ✓ No limit in cascading.
- ✓ Integrated switchable termination.
- ✓ Diagnostic LEDs.
- ✓ DB9 connector for measurements.
- ✓ IP 20 with DIN-rail mounting.

[www.procentec.com/profihub/b1/en](http://www.procentec.com/profihub/b1/en)